



OPTIMIZATION DESIGN OF CONFIGURATION FOR SINGLE-LAYER RIGID ROGOWSKI COILS

H. M. Wang^{1,2}, H. L. Zhang¹, S. X. Zheng¹

¹ Department of Optoelectronics Engineering, Yanshan University, Qinhuangdao China

² Hebei Normal University of Science and Technology, Qinhuangdao China

Abstract: Rogowski coil is an important part of a high voltage electronic current transformer. When accurate measurements are required, the single-layer rigid coil is a valuable consideration. This paper presents a particular description of single-layer rigid Rogowski coil having a rectangular cross section. The relations among the coil's parameters are formulated. In order to improve the coil's performance, the mathematical model for optimizing the coil's configuration is proposed, which is mainly expressed as a computational process finding the minimum of constrained nonlinear multivariable function. The coil's return-loop for minimizing electromagnetic interference is discussed briefly; its equation used to determine the position is more accurate than that used previously. Full optimization design is shown in a flow chart and its steps can be performed on program MATLAB. Finally, an application demonstrates the difference between the usual design and the optimization design.

Key Words: Current measurement/Single-layer/Rogowski coil/Optimization Design/Mathematical model

1. INTRODUCTION

Rogowski coil is an important component in a high voltage electronic current transformer. They were introduced to measure magnetic fields in 1912. At that time, they could not be used for current measurements because coils output voltage and power were not sufficient to drive the measuring equipment burden. With the improvement of today's microprocessor and optic fiber technology, Rogowski coils are more suitable for measuring high voltage AC current and transient current in power industry [1,2].

Rogowski coils may be wound having a single-layer winding or multiple-layer windings. The disadvantage of multiple-layer Rogowski coils is poorer performance with increasing frequency because the distributed capacitance and the series self-inductance of coil increase with the number of turns. Therefore, many researchers proposed that employment of the single-layer

coils is a valuable consideration when accurate measurement is required [3-5].

Single-layer Rogowski coils have lower value of mutual inductance M , series self-inductance L , series resistance r and distributed capacitance C_0 . The coils bandwidth is influenced by the resonant frequency of the circuit constructed using L and C_0 , which is given by

$$f = \frac{1}{2\pi\sqrt{LC_0}} \quad (1)$$

The measurement precision of Rogowski coils has a close relation to its upper limit of bandwidth. In order to achieve a high bandwidth, the resonant frequency should be increased [4,6].

We can arrange the coils configuration to obtain a mutual inductance required by using the shortest winding wire because the shorter wire means a lower distributed capacitance, a lower self-inductance, and a higher resonant frequency. The other reason for using the shortest winding wire to achieve the maximum mutual inductance is a consideration of thermal expansion effect on Rogowski coils [7,8]. The coils induced voltage error from thermal expansion effect on a shorter winding wire should be lower than that from a longer winding wire.

The main purpose of this paper is to investigate a kind of optimization method, to make single-layer Rogowski coils have the maximum mutual inductance employing the shortest winding wire.

2. PARAMETERS OF ROGOWSKI COILS CONFIGURATION

In order to obtain a high precision of current measurement, Rogowski coils are made with a rigid former because the rigid coils can provide better accuracy than that of the flexible coils [6]. Fig.1 shows a single-layer rigid Rogowski coil having a rectangular cross section. A current-carrying conductor is surrounded by Rogowski coil.

We can use the configuration parameters in Table 1 as the description of the coils structure. These parameters and relations among them will be used in following chapter and section without explanation.

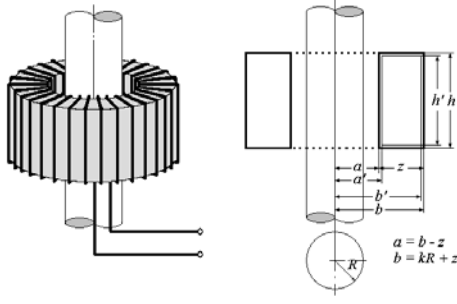

Fig. 1 Rogowski coil with a rectangular cross section and parameters of the coils configuration

Table 1. Parameters of Rogowski coils configuration and relations among these parameters

Sym.	Description	Relation	Unit
M	mutual inductance of Rogowski coils	$M = \frac{\mu_0 wh}{2\pi} \ln \frac{b}{a}$	H
d	diameter of winding wire	$d w = 2\pi a$	m
R	radii of the conductor measured		m
k	assemblage gap factor	$a = kR, k > 1$	
g	assemblage gap between coils and conductor	$g = a - R$	m
w	total number of turns	$w = 2\pi a/d$	
a	inner radii of Rogowski coils		m
b	outer radii of Rogowski coils		m
h	height of coils in axis direction		m
z	thickness of coils in radial direction	$z = b - a$	m
c	length of one turn winding wire	$c = 2(h + z)$	m
l	length of winding wire	$l = wc$	m
a'	inner radii of former	$a' = a + d/2$	m
b'	outer radii of former	$b' = b - d/2$	m
h'	height of former in axis direction	$h' = h - d$	m
z'	thickness of former in radial direction	$z' = z - d$	m
r_c	radii of the return loop for compensation	$r_c = \sqrt{ab}$	m

3. OPTIMIZATION OF ROGOWSKI COIL'S CONFIGURATION

The optimization design of Rogowski coils focuses on aspects of the coils configuration, which consist of coils winding, coils former, electromagnetic interference and so on.

3.1. Basic mathematical model

In the case of toroidal coils having a rectangular cross section such as that shown in Fig. 1, the mutual inductance is given by [6]

$$M = \frac{\mu_0 wh}{2\pi} \ln\left(\frac{b}{a}\right) \quad (2)$$

where μ_0 is the permeability of free space, $\mu_0 = 4\pi \times 10^{-7}$ H/m. From (2) we conclude that M is dependent on the coil configuration, a , b , h and w . In other words, we can fabricate Rogowski coils having a mutual inductance M using different combinations of a , b , h and w and there should be an arrangement employing the shortest winding wire.

By substituting relations in Table 1 for (2), we can obtain a crucial equation as

$$M = \frac{\mu_0 kR h}{d} \ln\left(\frac{kR + z}{kR}\right) \quad (3)$$

Equation (3) includes all information of Rogowski coils configuration. M is a multivariable function of arguments (h , z , R , k , d). It is also clear that there must be many points (h , z , R , k , d) keeping M a constant, and M is commonly required from the description of design.

For succinctness of this problem, the multivariables are classified into two groups: (R , k , d) and (h , z). The parameters, (R , k , d), are determined by practical situation, and the parameters, (h , z), are designed by optimization principle. There should be many optimization principles that suit for different purposes and different measurement requirements. In this paper, the optimization rule is to obtain the maximum mutual inductance M employing the minimum length of winding wire. We perform this optimization rule by building a mathematical model finding the minimum of a constrained nonlinear multivariable function.

When Rogowski coils are placed on a current-carrying conductor, the induced voltage, $u(t)$, over the coils terminals is proportional to the coils mutual inductance, M , and the rate of change of current, di/dt , and it is given by

$$u(t) = -M \frac{di}{dt} \quad (4)$$

Based on (3) and (4), a basic mathematical model for optimization design of Rogowski coils configuration is expressed as

$$\begin{aligned} \min \quad & f(h, z) = 2(h + z) \\ \text{subject to} \quad & \begin{cases} M = \frac{\mu_0 kR h}{d} \ln\left(\frac{kR + z}{kR}\right) \\ u(t) = -M \frac{di}{dt} \end{cases} \end{aligned} \quad (5)$$

The solution of (5) will give data, (h , z). Furtherly the parameters of former configuration can be obtained by using the relations in Table 1.

3.2. Minimizing electromagnetic interference

The pitch advancement of the winding makes the circumferential length and an undesirable one-turn loop is created. Any magnetic flux passing through this loop may induce an error voltage into the coil's output. The

magnetic flux passing through this loop can originate from the bus-bar geometry, nearby return conductors, other current carrying conductors, and the leakage flux from transformers. To prevent influence of the undesired magnetic flux coming from outside the loop, Rogowski coils must be designed with two-wire loops connected in electrically opposite directions.

Fig. 2 shows another one-turn loop, which is placed inside of the helical windings in the opposite direction to that of the pitch advancement turn. It is connected electrically in series with the coils output. The radial position of return loop is given by

$$r_c = \sqrt{ab} \quad (6)$$

Equation (6) is derived from that the area around by return loop is equal to the shadow area created by the toroidal projection in axis direction.

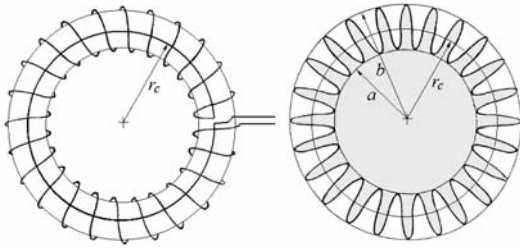

Fig.2 Position of return loop within Rogowski coils

Equation (6) is different from the common concept that the radial position of return loop is decided by $(a+b)/2$ or $\sqrt{(a^2+b^2)}/2$, which equal to an average of coils inner radii and outer radii or equal to an average of area encircled by inner circumference and outer circumference. Equation (6) gives a more accurate location for the return loop.

3.3 Overall flow chart of the design

Based on the discussion above, we present a flow chart, which describes the optimization design of the coils configuration briefly. The key steps of optimization design are shown in Fig. 3.

The first step is to determine coils output voltage under rated current (V/A). This is a basic expression of the requirements in designing Rogowski coils. The coils sense electric current through a changing magnetic field produced by the changing current. The induced voltage is linear with current and independent of the current magnitude.

The second step is to determine the coils mutual inductance (M). It is an important parameter of Rogowski coils in describing the coils sensitivity. The induced voltage of Rogowski coil is dependant on its mutual inductance and the frequency of measurement current

The third step is to determine the parameters requirement based on practical situation. These parameters include radii of the current-carrying conductor R , assemblage gap factor k and diameter of the winding wire d . The assemblage gap factor k can be

adjusted proved resulting data do not meet the need of design or fail the final verification.

The fourth step is the solution of variables (h, z). It is a computational process of constrained nonlinear multivariable function. This process is given by (5) in MATLAB version.

The fifth step is solution of data (a, b, h). This step is a conversion from data (h, z, a, k) to data (a, b, h), which is the familiar format in equation (2).

The sixth step is to determine the position of return loop. The radii of the compensation loop are designed based on equation (6).

The seventh step is to determine a dimension of former structure. The former data (a', b', h') is dependent on the winding configuration and the position of the return loop. The relations used in this step are shown in Table 1.

The eighth step is to verify the feasibility of the data from optimization design. Designer can modify the coil's configuration by resetting the assemblage gap factor k and repeat the steps. This process of finding coils configuration can be ended in the case of the data feasible.

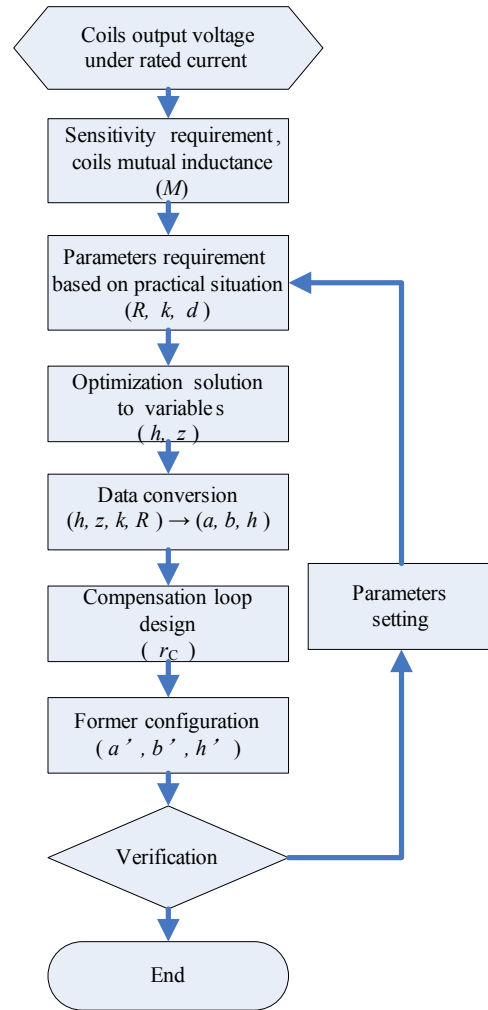

Fig. 3 Overall flow chart of Rogowski coils optimization design

4. APPLICATION

A considered Rogowski coil is integrated by series of two sub coils. The sub coils are identical to each other. The required induced voltage of the Rogowski coil is up to 0.75Vp-p under the rated current 1000A at power frequency 50Hz. From the requirement description above, we know that the voltage output over the terminal of each sub coil is 0.375Vp-p.

Starting with a set of parameters, specified $d=0.0002\text{m}$, $R=0.022\text{m}$ and $k=1.10$, we obtain the resulting data in Table 2 on program MATLAB. The key resultant data are the point: $(h, z) = (0.0141, 0.0117)$. The meaning of data is well illustrated in Fig.4. It shows the objective function and constraint function running closely with the point (h, z) . We can also start with other specified parameters and obtain different coils configuration.

In Table 2, two groups of coils configuration show the difference between the optimization design and the usual design. The data listed of coil A are produced from optimization program, and data of coils B are not. It is obvious that the winding wire of coils B is longer than that of coils A. The length of winding wire on coils A is approximately 3.0 % shorter than that of coils B. The shorter wire means the lower distributed capacitance, self-inductance, and higher resonant frequency.

Furthermore, the height of coils A also benefits the frequency performance in that the closely parallel winding wires situated at inner side of the coils allow a theoretical 19.9 % decrease of that on coils B.

Table 2. List of Rogowski coil's parameters

Parameter	Coils A	Coils B	$\frac{A-B}{B}$
M	$0.845 \times 10^{-6} \text{H}$	$0.845 \times 10^{-6} \text{H}$	
d	$2 \times 10^{-4} \text{m}$	$2 \times 10^{-4} \text{m}$	
R	0.0220m	0.0220m	
k	1.10	1.10	
g	0.0022m	0.0022m	
w	760	760	
a	0.0242m	0.0242m	
b	0.0359m	0.0332m	+8.1%
h	0.0141m	0.0176m	-19.9%
z	0.0117m	0.0090m	
c	0.0516m	0.0532m	
l	39.216m	40.432m	-3.0%
a'	0.0243m	0.0243m	
b'	0.0358m	0.0331m	
h'	0.0139m	0.0174m	
z'	0.0115m	0.0088m	
r_c	0.0295m	0.0283m	

5. CONCLUSION

A particular description of single-layer rigid Rogowski coil having a rectangular cross section is presented. The mathematical model for optimizing coil's configuration is proposed as a computational process finding the minimum of a constrained nonlinear multivariable function. Full optimization design is shown

in a flow chart and its steps can be performed on program MATLAB.

An application demonstrates the difference between the usual design and optimization design. The optimization method is helpful in designing Rogowski coils transformer.

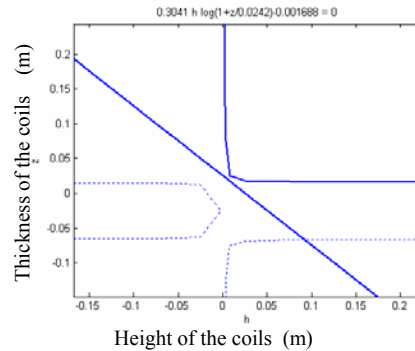

Fig. 4 Objective function and constraint function close with the point (h, z) .

ACKNOWLEDGMENT

This work is supported by the National Natural Science Foundation of China: No 50477001.

REFERENCES

- [1] D.A.Ward, J. La T. Exon, "Using Rogowski coils for transient current measurements," Engineering Science and Educational Journal, June 1993 Vol.2, Issue: 3 , pp.105 - 113
- [2] S.X. Zheng, X.Lu, F.Liu, Q.Z.Lu, "An Active Optical Fiber Current Transducer," Proc.SPIE 2002 Vol.4920 pp. 405-409
- [3] A. Rautiainen, P.Helisto, T.Mansten and H.Seppa, "50 Hz current measurements with Rogowski coils," Precision Electromagnetic Measurements, 2002. Conference Digest 2002 Conference , June 2002, pp.230 - 231
- [4] X.H.Guo, J.S.Liao, M.J.Zhu and M.Y.Ye, "Improved performance Rogowski coils for power system," Transmission and Distribution Conference and Exposition, 2003 IEEE PES, Sept. 2003, Vol.1, pp. 371 - 374
- [5] L.Kojovic, " PCB Rogowski coil designs and performances for novel protective relaying," Power Engineering Society General Meeting, IEEE July 2003, Vol.2 pp.13-17
- [6] J.D. Ramboz, "Machinable Rogowski coil, design, and calibration," Instrumentation and Measurement IEEE transactions April 1996 Vol.45, pp 511-515.
- [7] H.M. Wang, S.X. Zheng, "Methods for improving the measurement precision of the Rogowski coils," 6th International Symposium on Test and Measurement, Conference Proceedings, ISTM 2005, Vol.3 pp.2789-2792
- [8] H.M.Wang, F.Liu, H.L.Zhang, S.X.Zheng, "Analysis of Thermal Expansion Effect on Measurement Precision of Rogowski Coils," accepted paper, IEEE PEDS 2005.