



APPLICATION OF SHAFT-SENSORLESS INDUCTION MOTOR DRIVE IN A WASHING-MACHINE

Darko P. Marčetić, Vladan R. Jevremović*

Faculty of Technical Sciences, University of Novi Sad, Novi Sad, Serbia

*SR Drives Ltd – Emerson Motor Technologies, Harrogate, United Kingdom

Abstract: This paper presents the vector controlled induction motor (IM) drive suitable for high-end washing-machine applications. Firstly, the main features of a washing-machine drive application are discussed, such as the required motor torque-speed characteristic, specific torque ripple and dynamic performance during motor startup and low speed operation. Secondly, Indirect Field Oriented Control (IFOC) drive with Model Reference Adjustable System (MRAS) speed estimator is proposed. The drive is shaft-sensorless and operates with single shunt resistor in DC link. The overall system price is highly competitive, and it can be a suitable replacement for a traditional scalar controlled drive. To insure robust and optimal sensorless operation in low speed range, two simple yet practical solutions are proposed. Both solutions are experimentally verified.

Key Words: washing-machine, induction motor drive, sensorless control, MRAS

1. INTRODUCTION

Modern high performance washing-machine drives can be made possible only by implementation of the vector control technique. The vector controlled IM drive can achieve high drum speed dynamic performance, advanced flux control in wash; and optimal field-weakening operation in spin. Vector controlled drive also offers robust motor control using minimum number of sensors, which makes it more favorable than old-fashioned scalar controlled drive [1]. Scalar drive is still highly applicable in the today's washing-machines mainly due to its low price. Fierce competition on the appliance market does not permit almost any drive price growth; however more robust drive operation is always welcome. Consistent price reductions of motor control Digital Signal Processors (DSP), capable of running advanced shaft-sensorless vector control algorithms, finally encouraged the use of vector controlled drives for the latest washing-machine applications. The design of IM drive for a high-end washing-machine is not a straightforward task [2]. Firstly, one must account extremely low drive price, limited number of sensors, simple power supply, single layer printed circuit board and low-cost DSP with limited computational capabilities and memory. Secondly, several application requirements, all directly resulting from wide speed

range operation, have to be addressed. In the front-load washing-machine the motor torque is usually transferred from the motor shaft to a drum using belted transmission, with typical belt transfer ratio from 11:1 to 14:1. Consequently, motor speed is higher than drum speed, while motor torque is lower than drum torque. Typical washing-machine torque-speed characteristic for the motor applied in front-load washing-machine with the belt system is shown on Fig 1.

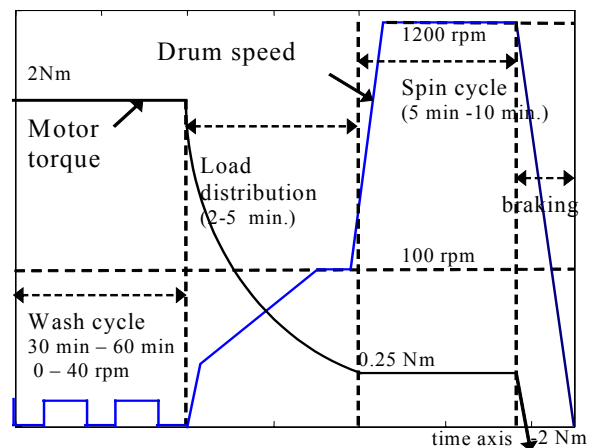

Fig. 1. Typical wash cycle showing motor torque vs. drum speed.

The required characteristic is specified for wide speed range. One can clearly distinguish two modes of operation - wash (low speed) and spin (high speed) cycle. Typically, washing-machine mostly operates in wash cycle, having high torque startup every 15 seconds, and high steady state torque. During that phase, significant motor temperature rise and large motor parameter variations can be expected. On the other hand, spin cycle is mainly used for water extraction and it has low torque but high power requirements.

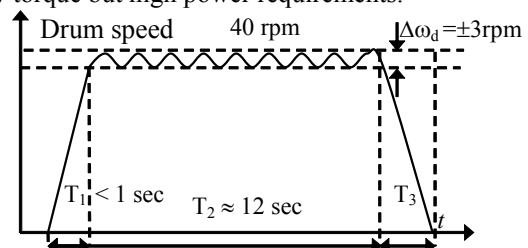

Fig. 2. Typical speed profile during the wash cycle

This paper addresses only problems associated with the shaft-sensorless drive operation in wash cycle (Fig. 2). Beside tight speed control requirement in the presence of high torque ripple, there are two other, diametrically opposite requirements - fast ramp-up of the drum speed during the startup phase (T_1) and optimal flux level setup during the motor run phase. Obviously, superior dynamic performance of the vector controlled drive can improve the speed ripple but it is also the best solution for the other two listed requirements. We are proposing a simple shaft-sensorless vector controlled IM drive with minimal number of sensors, capable of giving high starting torque. The drive is additionally equipped with simple flux controller, which adapts flux level to the actual mechanical load and insures minimal motor losses.

2. MRAS SPEED ESTIMATOR WITH MINIMUM NUMBER OF SENSORS

In order to be competitive in the appliance market, the washing-machine drive has to be shaft-sensorless and based on a low cost DSP or microcontroller. Having that in mind, advanced speed estimation associated with high-end processors, expensive peripherals and power supply circuitry should be avoided [3]. Shaft-sensorless algorithm of our choice is simple MRAS speed estimator based on two rotor flux models with different structures [4]. The reference (voltage) model and the adjustable (current) rotor flux model are given in (1) and (2), respectively. The error signal used for tuning of the estimated speed is phase angle between two flux vectors (3).

$$p\vec{\psi}_r^{vi} = \frac{L_r}{L_m}(\vec{v}_s - (R_s + \sigma L_s p)\vec{i}_s) \quad (1)$$

$$p\vec{\psi}_r^{oi} = \frac{L_m}{T_r}\vec{i}_s - \left(\frac{1}{T_r} - j\hat{\omega}_r\right)\vec{\psi}_r^{oi} \quad (2)$$

$$\varepsilon = \vec{\psi}_r^{oi} \times \vec{\psi}_r^{vi} = \psi_{\alpha r}^{oi}\psi_{\beta r}^{vi} - \psi_{\beta r}^{oi}\psi_{\alpha r}^{vi} \quad (3)$$

where

$$\vec{\psi}_r^{vi} = [\psi_{\alpha r}^{vi} \ \psi_{\beta r}^{vi}]^T, \vec{\psi}_r^{oi} = [\psi_{\alpha r}^{oi} \ \psi_{\beta r}^{oi}]^T, \vec{v}_s = [v_{\alpha s} \ v_{\beta s}]^T,$$

$\vec{i}_s = [i_{\alpha s} \ i_{\beta s}]^T$ are outputs of the rotor flux voltage and current model, stator voltages and currents, respectively; $\hat{\omega}_r$ is estimated rotor angular frequency; L_m , L_s , L_r are magnetizing, stator and rotor inductances; $\sigma = 1 - L_m^2/L_s L_r$ is total leakage factor. Equations (1)-(3) are defined in stationary reference (α - β) frame.

In order to match the phase angle between two estimated rotor flux vectors, the MRAS error signal is fed to the linear regulator (Fig. 3) which in turn tunes the estimated speed variable and hence performs the correction of the model (2) result.

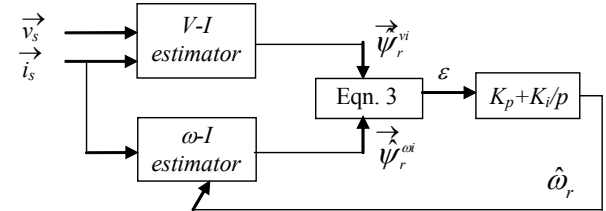

Fig. 3. Block diagram of MRAS speed estimator

MRAS speed estimator eliminates the need for expensive speed sensor. Usage of sensors in the drive is also minimized, whenever it is possible. Phase voltages are not measured; they are rather reconstructed using PWM pattern and measured DC link voltage. Only DC link current is measured with simple shunt resistor, and used for the phase currents reconstruction [5]. Block diagram of the system with minimal number of sensors, is given in Fig 4.

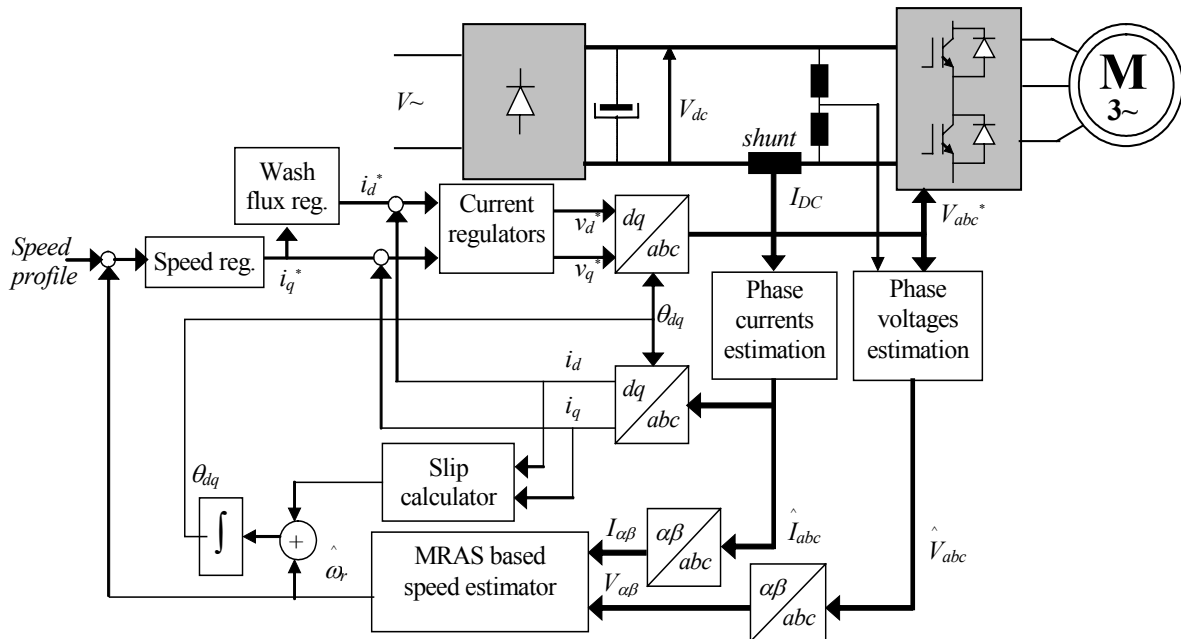

Fig. 4. Block diagram of shaft-sensorless induction motor drive with minimal number of sensors and MRAS speed estimator

3. SIMPLE SOLUTION FOR SENSORLESS MOTOR STARTUP

Washing-machine shaft-sensorless drive application is most demanding during the motor startup. Specified drum speed rise time is relatively short, and has to be accomplished with high starting torque. The problem gets more complex for shaft-sensorless drive which estimates rotor position using available motor terminal quantities. For low speeds, including standstill, the rotor-induced voltage diminishes on stator terminals making MRAS speed estimate sensitive to the stator voltage and stator resistance voltage drop estimation errors. To avoid unstable speed and position estimation, the stator voltage estimation must include all the inverter nonlinearity effects, such as the switching devices dead-time and conducting voltage drop [6]. Also, stator resistance thermal drift has to be taken into account. For a washing-machine application, one can take advantage of motor wash duty cycle, having relatively long stoppage time between two runs. During stoppage, the stator resistance can be measured with simple DC current injection [7]. However, low stator frequency during the motor startup causes additional problem, originating in MRAS usage of quasi integrators. The quasi integrators $1/(p+\omega_1)$, used to suppress oscillations in estimated reference flux, create an unwanted phase lag, especially for frequencies close to or below the cut-off frequency ω_1 . This can be canceled for frequencies above the ω_1 , by using the first order filter to process the current vector signal, as it is shown in Fig 5.

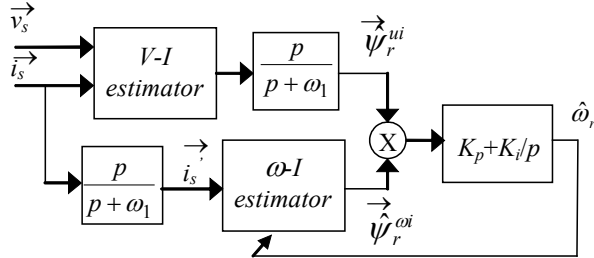

Fig.5. Modified MRAS speed estimation scheme

This compensation does not work well for frequencies below the cut-off frequency. The proposed motor startup solution is simple and suggests that these frequencies should be avoided. Before the run, both stator current d-q references must be set to their nominal values. The speed estimator should be stopped ($\hat{\omega}_r = 0$) until the actual current values get close to the reference values, when also output stator frequency should have exceeded the cut-off frequency, set in drive to 1Hz.

$$\omega_s = \hat{\omega}_r + \frac{1}{T_r^*} \frac{I_q}{I_d} = \frac{1}{T_r^*} \frac{I_q}{I_d} > \omega_1 = 2\pi \text{ rad} / \text{s} \quad (4)$$

With the rotor time constant close to 100ms, and $I_q \approx I_d$, starting stator frequency is already above the cut-off frequency and rotor speed estimator can start.

4. OPTIMAL FLUX LEVEL CONTROL DURING WASH CYCLE

During the wash cycle motor can heat up to the highest temperature point in the entire cycle. To prevent extensive motor heat-up, especially above the rated 150 C°, the flux reference (I_d^*) optimization criteria in wash phase must be the minimization of overall motor losses. The washing machine drive is speed controlled, and in the steady state the achieved electrical torque must be equal to the load torque.

$$T_{el} = K_t \Psi_d I_q = K_{t1} I_d I_q = T_{load} \quad (5)$$

But, there is still one degree of freedom for d and q current reference selection, which can be used for rotor flux level optimization. Most of the motor losses during the low speed wash cycle are the resistive losses (6), (7).

$$P_{losses} \approx P_{cu} = R_s (I_d^2 + I_q^2) \quad (6)$$

$$P_{cu} = R_s \left(\left(\frac{T_{load}}{K_{t1}} \right)^2 \frac{1}{I_q^2} + I_q^2 \right) \quad (7)$$

Minimizing only resistive losses would still be sufficient to bring the overall motor losses in wash cycle to the acceptable level. Minimum resistive losses

$$\frac{dP_{cu}}{dI_q} = R_s \left(-2 \left(\frac{T_{load}}{K_{t1}} \right)^2 \frac{1}{I_q^3} + 2I_q \right) = 0 \quad (8)$$

can be obtained for

$$I_q = \sqrt{\frac{T_{load}}{K_{t1}}} \quad (9)$$

Using (5) and (9), I_d and I_q values that insure optimal flux level for any given load torque can be found as:

$$I_d = I_q = \sqrt{\frac{T_{load}}{K_{t1}}} \quad (10)$$

Direct assignment of I_q^* to the flux current reference I_d^* would deteriorate the speed control dynamics and cannot be applied in practice. Instead, a simple integral action can be used:

$$I_d^*(k) = I_d^*(k-1) + K_f (I_q^*(k-1) - I_d^*(k-1)) \quad (11)$$

The selection criteria for the flux loop gain K_f must address the short run time during the wash cycle. In practice flux reference must adapt to the steady state load value within the first two to three seconds after the start.

Sense the drive now has variable d-axis current command, MRAS parameters (L_m , T_r) should be altered with the change of the main flux saturation level [8].

5. EXPERIMENTAL RESULTS

The induction motor (rated power 700W, rated voltage 195V, Δ connection, two poles, $R_s = 9.1\Omega$, $R_r = 5.73\Omega$, $L_m = 0.585\text{H}$, $L_s = 0.615\text{H}$, $L_r = 0.615\text{H}$, $\sigma L_s = 0.058\text{H}$, under rated conditions) was loaded with MAGTROL 5410 dynamometer. Three-phase voltage source inverter was controlled digitally, using the low-cost Freescale DSP 56F8013 at 32MHz with 16k flash memory. DC link current was measured using single shunt in DC link circuit and phase currents were reconstructed from that

signal. The motor voltage was estimated using DC link voltage samples and the PWM duty cycles, with the compensation of dead-time and voltage drop on switching devices. The PWM frequency was set to 15.6 kHz, which is the same sampling frequency for all other calculations: phase currents reconstruction, phase voltages estimation, MRAS rotor speed and position estimator. Speed and flux controllers operate at sampling frequency of 200Hz. The cut-off frequency of quasi integrators used in MRAS was set to 1Hz. Bandwidths of speed and current control loops are set to 20Hz and 200Hz, respectively. The rotor speed was monitored for verification purposes using AC tachometer. The effectiveness of the proposed shaft-sensorless scheme can be well demonstrated with two experimental results, showing relevant signals during the motor startup with minimum and nominal load torque on the shaft.

Figures 6-7 show: motor rotor speed (commanded value is 540 rpm - 13.5:1 belt ratio and 40 rpm drum speed), estimated torque, and average stator d and q axis current. In both cases, fast drum speed ramp-up is achieved. Drum speed settle time in both cases is about 700 ms, which is below usually specified drum speed ramp-up time. Also, for the motor free shaft startup, one can note prompt flux reference excursion to the lowest allowed value (0.55A). At that point, motor has steady state speed around 540 rpm, running with only 15 Vrms, which is set as the absolute lowest limit to achieve optimal single DC shunt reading. The motor losses can be neglected, since the flux level saturation is avoided. Quite the opposite,

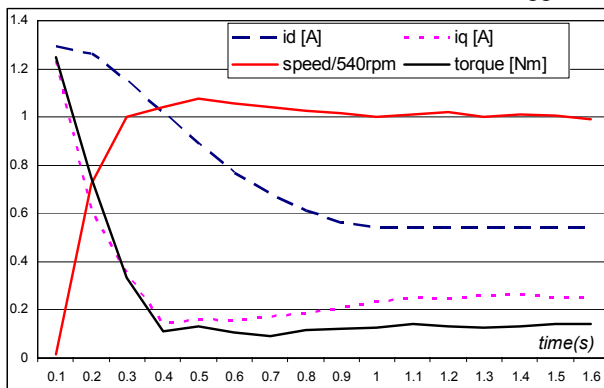

Fig. 6. Motor speed, torque and current waveforms for low load start

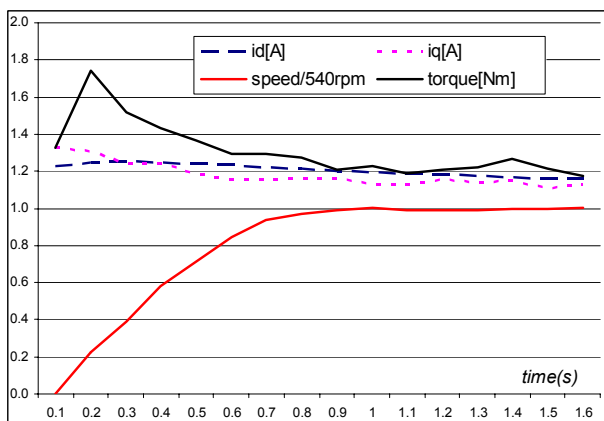

Fig. 7. Motor speed, torque and current waveforms for nominal load start

for high load start, one can note parallel traces of both stator current components. Flux reference has slower dynamics, as it is expected from (10). At the steady state, motor speed settles at 540 rpm, with the optimal flux level set to mechanical load on the shaft. Any other arbitrarily selected flux reference increases the motor input power, and consequently the motor losses.

6. CONCLUSION

In this paper, a simple shaft-sensorless drive solution for washing-machine application is proposed. All the drive features are specified under the assumption of price restriction. The selected shaft-sensorless MRAS algorithm is not computationally intensive and does not require significant processor power. Major MRAS drawback, which is the operation with stator frequency lower than quasi integrators cut-off frequency, is simply avoided. In addition, this solution increases the starting torque and decreases the ramp-up time. Finally, the control software is improved by adding simple flux reference regulator which insures minimum motor losses during wash cycle. The flux regulator operates in parallel with speed regulator, and adapts drive performance to the load right from the startup.

7. REFERENCES

- [1] J. Holtz, "Methods for speed sensorless control of AC drives", Sensorless Control of AC motors, IEEE Press Book, 1996.
- [2] Z. Zhang, H. Xu, L. Xu, L. E. Heilman, "Sensorless Direct Field-Oriented Control of Three-Phase Induction Motors Based on "Sliding Mode" for Washing-Machine Drive Applications", IEEE Trans. Ind. Appl., vol. 42, no. 3, pp. 694-701, May/June, 2006.
- [3] J. Holtz, "Sensorless Control of Induction Machines — With or Without Signal Injection?", IEEE Trans. Ind. Electron., vol. 53, no. 1, pp. 7-30, Feb. 2006.
- [4] C. Schauder, "Adaptive speed identification for vector control of induction motors without rotational transducers", IEEE Trans. Ind. Appl., vol. 28, no. 5, pp. 1054-1061, Sept/Oct, 1992.
- [5] H. Kim, T. M. Jahns, "Phase Current Reconstruction for AC Motor Drives Using a DC Link Single Current Sensor and Measurement Voltage Vectors", IEEE Trans. Power Electron., vol. 21, no. 5, pp. 1413-1419, Sept. 2006.
- [6] J. Holtz, J. Quan, "Drift and Parameter Compensated Flux Estimator for Persistent Zero Stator Frequency Operation of Sensorless Controlled Induction Motors", IEEE Trans. Ind. Appl., vol. 39, no. 4, pp. 1052-1060, July/Aug. 2003.
- [7] S. Thorn, et. al., "Estimation of Motor Temperature From Terminal Voltages and Automatic Calibration Thereof", Emerson Electric Patent No. EMC-04-023, 2005.
- [8] E. Levi and M. Wang, "A Speed Estimator for High Performance Sensorless Control of Induction Motors in the Field Weakening Region", IEEE Trans. Power Electron., vol. 17, No 3, pp 365-377, May, 2002.