



# POWER ELECTRONICS FOR MW WIND TURBINES

Dejan Schreiber

SEMIKRON Elektronik GmbH & Co.KG Nuremberg, Germany

**Abstract:** Efficient use of wind energy and its conversion in electric energy is provided through power electronics, using exclusively power electronics converters and generators based on low voltage levels. Medium Voltage generator is better solution for high power. The paper reviews the status and proposes a new principle for the use of medium voltage generators - a grid-side medium voltage inverter based on the cell principle, using standard, proven semiconductors.

**Keywords:** Windmills / Power Electronics / Medium Voltage generator / IGBT

## 1. INTRODUCTION

Windmill is the world's fastest-growing power generating technology today, with about 130 GW of installed capacities worldwide. SEMIKRON has been very active in the wind turbine power electronics business for the last 15 years and introduces user-friendly power system platform with SKiiP technology, [1] and stack assembly. All exciting wind turbine converter constructions are based on low voltage generators as well as on low voltage silicon. A number of factors are important in wind-power applications. Efficiency is, of course, key. The power converters must take a quasi-sinusoidal current from the generator and convert this to a sinusoidal current for the grid, with the minimum of losses. The converters must offer reactive power control, to cope with variations in line power factor, and operate in conditions of network disturbance and network short-circuit. They must also produce very low levels of total harmonic distortion. Connection to the distribution network should be via a simple line transformer.

## 2. APPLIED CIRCUITRY

The fundamental questions in windmill power electronics design is the operating principle of the wind turbines. WT manufactures are categorized, according to the principles of operation of their wind turbines. [2]. In use are:

1. Rotor cascade circuit, with DFIG Double Fed Induction Generator. This setting seems to offer less power electronics power, good efficiency

coefficient at full power (when there is a plenty of wind), but has a very poor efficiency coefficient at lower wind speeds, as well as short service lifetime of the rotor slip rings. Despite all this, the principle is widespread, mainly due to the fact that it was developed long ago (in the previous century) and is still used by the leading WT manufacturers.

2. Synchronous generator, PMG, as well as externally excited generator, but also a classic asynchronous motor, are the generators used in new wind turbine solutions. Synchronous generators can be used with or without a gearbox. Synchronous and asynchronous generators require two serially connected power electronics converters, both for full wind turbine power. All new solutions introduced by experienced windmill manufacturers are using the full size inverters, with total power flow through power semiconductors. Only starter companies, especially the ones from Far East, are still trying to develop their first wind turbines based on the first principle.

## 3. HIGH POWER DESIGN

High power inverter design needs a lot of IGBT chips & modules. The solutions for parallel operation of the IGBT modules are: [3]

1. One unit for the whole power. One driver and a lot of IGBT Modules in parallel. Each IGBT Module has its own gate resistors. One controller is in use.
2. Paralleling of inverter legs. Several gate drivers are driving a several inverter legs connected in parallel. One PWM signal is connected to each inverter leg driver, via paralleling board. [4] Per each half-bridge, inverter leg in use is little AC choke because of different driver propagation times.
3. One PWM signal from one controller is drawing several three phase inverter in parallel, (via paralleling boards, for example). Each inverter has separate DC link fuses, as well as inverter output chokes.

- Galvanic isolation on generator side; separate three phase generator windings, DC links, generator & grid side inverters and controllers. Windmill operates even when one system is out of function!

Generator with a lot of phases has a lot of advantages. Generator with 3 times three windings, 9 phases and three independent drives is shown in Fig. 1

In use today are the high power generators for example of 4.5MW, with six three phase windings and 18 phases, controlled via six 4 Quadrant drives.

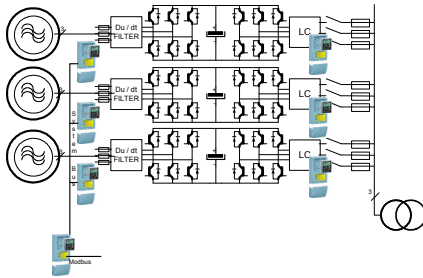

Fig. 1 Parallel operation of three drives

#### 4. GRID INTEGRATION

Wind power plants could feature ‘virtual power plant’ operation characteristics, which means that they would fulfill grid code requirements with respect to active power control, reactive power and voltage control, and fault ride through capability.

Low voltage ride-through technology of several WT manufacturers is shown. SEMIKRON offers the calculations for the semiconductors in normal, as well as in Low Voltage Ride-Thru working conditions. The calculation can be performed online, at [www.semikron.com](http://www.semikron.com).

#### 5. PATENT RIGHTS ON WINDMILL DESIGN

Patent rights to wind turbine design play a significant role in wind turbine power electronics. Large windmill companies own wide-ranging patent rights, and therefore it is practically and theoretically impossible to avoid GE Wind patents in the US with standard wind turbine designs. Two biggest wind turbine producers, General Electric Wind Power and Enercon, have signed an agreement on exchange of worldwide patent rights.

#### 6. WIND TURBINE POWER ELECTRONICS SERVICE LIFETIME

Depending on the working conditions and the resulting variation of silicon virtual junction temperature,  $\Delta T_j$  of the semiconductor, material fatigue can set in, and the semiconductor can deteriorate. SK performs comprehensive tests to establish the correlation between  $\Delta T_j$  and the number of cycles for the modules with or without copper base plate.

How to assess the service lifetime of power electronics components?

What is required for the assessment of semiconductor lifetime?

- The data on the operating conditions over time - like load current, AC and DC voltages, carrier switching frequency [Fsw], output frequency and ambient temperature,
- Corresponding  $[\Delta T_j]$  for the IGBT and the diode can be calculated using this data and the SEMISEL Professional Simulation Tool, [5]
- Knowing  $[\Delta T_j]$ , and using the graph, for example on Fig. 2, the expected number of service cycles [Ncycles] can be established,
- The number of expected load cycles per year should be known [Nyear],
- The ratio  $[Ncycles/ Nyear]$  gives the estimated service lifetime for the IGBT and Diode Chips.

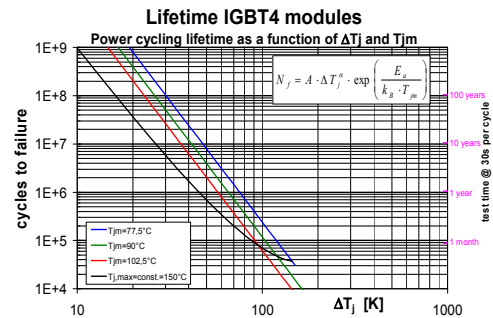

Fig.2 New IGBT4 lifetime characteristics

#### 7. EFFICIENCY OF POWER ELECTRONICS

IGBTs are the working horses of power electronics. Today, IGBTs are manufactured in various voltage classes – 1200 V, 1700 V for wide industrial application, and medium-voltage classes 3.3 kV, 4.5 kV, 6.5 kV. Which voltage class is the most suitable for high-power grid tied applications? The answer to this question is found when the mentioned IGBTs are put in the largest casing, module, available, in order to obtain inverters. Of course, it is much simpler to simulate available power that we can obtain under optimal working conditions.

The largest standard casing, IHM, 190 mm wide, is taken, in which all the mentioned IGBTs are packed, and if the optimal working regimes are defined -  $V_{dc}$  DC operational link voltage,  $V_{ac}$  AC output voltage, with a carrier switching frequency of 3.6 kHz, under best possible cooling conditions.

The results of calculations are showing different available powers in Fig. 3a

Three phase IGBT inverter operation at same cooling conditions  
 $F_{sw} = 3.6\text{kHz}$ ;  $\cos\phi = 0.9$  and same module size

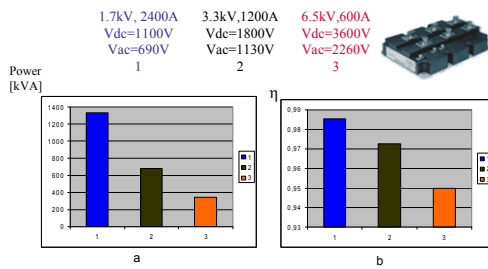

Fig. 3a,b Efficiency of power electronics components

Approximately, the results are showing that the maximum available power, using 3.3 kV, 1200 A single modules, would be one half of the equivalent power obtained using 1.7 kV, 2400 A IGBTs.

The 6.5 kV, 600 A IGBT modules provide just one quarter compared to the 1700 V IGBT.

The reasons behind these surprising results are the losses on IGBT modules. If we calculate the efficiency of these three converters, shown in Fig. 3b, we can see that the losses have ratios 1:2:4.

For this comparison, we have used the same carrier switching frequency,  $F_{sw} = 3.6\text{ kHz}$ . It provides us with the opportunity to design inverters with relatively small grid side sinusoidal filters. A comparison using different carrier switching frequencies would cause variations in used output sinusoidal filters. Based on all of the above, it can be seen that the greatest efficiency is accomplished with the application of the 1700 V IGBT, a standard industrial product with a very reasonable price per module & output power.

## 8. FUTURE DEVELOPMENTS

For medium-voltage generator in windmill applications, power electronics converters are non-standard and have to be developed specifically for the application. In the main, they do not have features in common with converters used in mass industrial applications.

High power wind turbines and low voltage (lower than 1000V) generators used for wind-power generators planned for new offshore applications are difficult to design because the generator currents are very high. For example, 5 MW at 3 x 660V produces a rated current of 4.2kA, which is a very high value, for cables and other system components. Therefore the logical solution would be to use medium voltage generators in the range of 6.3 kV or more. The rectifier DC voltage will be higher as 10kVDC, and there are no semiconductors available today for such applications. Multi level, three level inverters in use today, with MV silicon are on the DC voltage limits; Five or more level inverters are still a dream, not in use for industrial applications.

SEMIKRON has introduced Medium Voltage wind turbine grid side inverter based on the multi-cell principle, without upper DC voltage limits, with the use of proven semiconductors, 1700V IGBTs.

SEMIKRON patented the approach of setting several converters in serial/parallel to produce a medium voltage DC/AC converter in connection with grid side transformer for windmill connection to the medium / high grid voltage lines..

## 9. MV MW SOLUTION

- A medium voltage generator, preferable permanent magnet excited synchronous machine;
- A rectifier circuit arrangement for transforming the AC voltage produced in the generator into a medium range DC voltage;
- A DC connection in the medium-voltage range from the rectifier circuit arrangement to a power converter configured as a cascaded series-connected arrangement of three-phase power converter cells;
- A cell with three-phase line side inverter with By-Pass arrangement on the input;
- A cell controller keeping the cell DC link voltage constant;
- A high-voltage transformer for transforming the output voltages of the power converter cells into the voltage required for the power grid;
- The circuit diagram is shown on Fig.2
- A master control unit for the By Pass PWM control according to the generator torque demand. It controls the MV DC current on the way of bypassing one or more of cell. Bypassed cell can control the reactive power.
- Cell control is independent of the whole system; it controls only the cell DC voltage. [6]

### Features

- Generator operation DC voltage range from 1 kVDC to  $V_{dcmx} (>10\text{kVDC})$
- DC voltage per cell 1100V (1700V silicon) for 3 x 690VAC cell supply
- Number of Cells =  $V_{dcmx}/V_{cell}$
- Cell Power:  $P_{genmax}/\text{Number of Cells}$
- Redundancy of the system (+1)
- Cell switched-on time varies from 0% to 100%
- Switched-off Cell can produce full reactive power
- High efficiency at full & lower power
- Total Harmonic Distortion reduction using interleaving PWM
- Line side ripple frequency =  $N_{cell} * F_{swCell}$
- Simple line side transformer
- Low voltage ride-through capability

### Strengths

- Full variable speed
- Low voltage cells
- Wide DC voltage operation range
- Active & reactive power control
- High efficiency at low & high power
- High efficiency as by low voltage converters
- Excellent power quality
- No difference for 50/60Hz applications
- Modular design
- USA implementation

**Weaknesses**

- number of cells
- Special medium-voltage training for maintenance staff

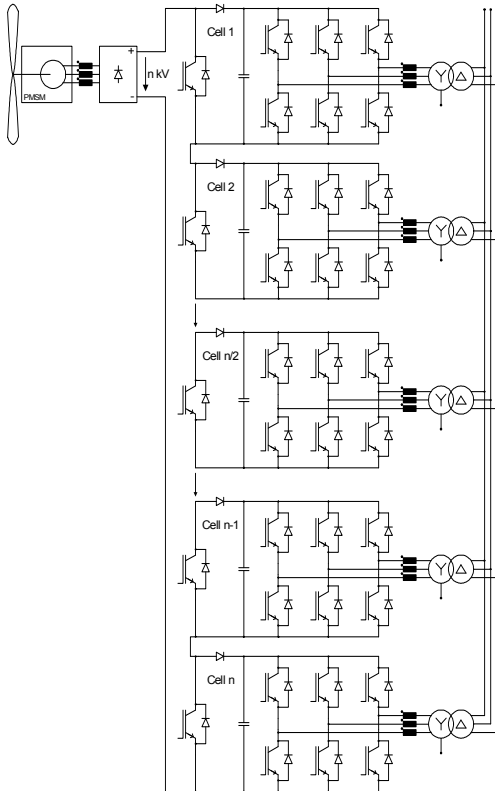

**Fig. 2** MV line side inverter for WT

**10. CONCLUSION**

- All new developments are based on variable speed windmill principle,
- All new developments of experienced windmill manufacturers use a permanent magnet generator and full size inverter,
- Only companies without experience with windmill applications are looking for double-fed construction,

- Active and reactive power control, and low voltage ride-thru technology are very effective in the full size inverter construction,
- Service lifetime of applied silicon can be predicted and controlled,
- 1700V IGBTs have highest efficiency today,
- The future of high-power wind turbine generators is in medium voltage ranges.

Medium voltage windmills using the cell principle have a future.

SEMIKRON has met requirements by developing a medium voltage converter design, based on a synchronous generator, (permanent magnet too) and a rectifier stage, connected to a cascaded serial arrangement of several (N) power converter cells. These cells are dynamically made active or inactive by a master control unit, depending on the power being generated by the windmill generator. Each cell supplies a three-phase primary winding of an output transformer. By using a modular construction for different power and voltage values, converters can be assembled quickly and can offer built-in redundancy for high reliability. MV Wind turbines and HVDC transmissions are the new power electronics challenge.

**11. REFERENCES**

- [1] P. Becketdahl, "SKiiP –An intelligent power module for wind turbine inverters" EPE Wind Energy Chapter, Stockholm April 2009
- [2] D. Schreiber "State of the Art of Variable Speed Wind Turbines" 11<sup>th</sup> INTERNATIONAL SYMPOSIUM on POWER ELECTRONICS-Ee2001 Novi Sad, YUGOSLAVIA, OCT.31-NOV. 2, 2001
- [3] D. Schreiber "Power Electronics for Windmill Application" Wind Power Asia Shanghai 2007
- [4] Parallel Board SKHB2,3,4 SEMIDRIVER Data Sheet SEMIKRON
- [5] Semisel Professional simulation tool [www.SEMIKRON.com](http://www.SEMIKRON.com)
- [6] D. Schreiber, P. Becketdahl, I. Staudt "Medim voltage line side inverter for windmill applications",EPE Wind Energy Chapter, Stockholm, April 2009