



COMPARATIVE STUDY OF TWO MULTILEVEL CONVERTERS FOR ENVELOPE AMPLIFIER

Miroslav Vasić, Oscar Garcia, Jesus Angel Oliver, Pedro Alou,
Daniel Diaz, Jose Antonio Cobos

Universidad Politécnica de Madrid, Centro de Electrónica Industrial, Madrid, Spain

miroslav.vasic@upm.es

Abstract: Modern transmitters usually have to amplify and transmit signals with simultaneous envelope and phase modulation. Due to this property of the transmitted signal, linear power amplifiers (class A, B or AB) are usually used as a solution for the power amplifier stage. These amplifiers have high linearity, but suffer from low efficiency when the transmitted signal has low peak-to-average power ratio. The Kahn envelope elimination and restoration (EER) technique is used to enhance efficiency of RF transmitters, by combining highly efficient, nonlinear RF amplifier (class D or E for example) with a highly efficient envelope amplifier in order to obtain linear and highly efficient RF amplifier. This paper compares two solutions for the envelope amplifier based on a combination of multilevel converter and linear regulator. The solutions are compared regarding their efficiency, size and weight. Both solutions can reproduce any signal with maximal spectral component of 2 MHz and give instantaneous maximal power of 50 W. The efficiency measurements show that when the signals with low average value are transmitted, the implemented prototypes have up to 20% higher efficiency than linear regulator that is used as a conventional solution.

Key Words: Power Amplifiers, Kahn's Tehcnique, Envelope Amplifiers

1. INTRODUCTION

In the modern world of today, the demand for broadband and wireless services is growing on a daily basis. One of direct consequences of this growth is certainly the growth of the networks that have to provide these services and the problem is their energy consumption. Some estimations showed that a 1% of planet's global energy consumption in 2007 was made by telecommunication industry [1]. In [2] is explained that the efficiency of the first generation 3G radio base stations is just few percents, and that the efficiency of the employed power amplifiers is just 6%. The impact of power amplifier's efficiency can be seen in the information that if the power amplifiers could improve its efficiency by 10% the overall efficiency would be raised by 6%.

One of the reasons for very low efficiency of linear power amplifiers is the transmitted signal's statistics. The

major part of the transmitted signals have high Peak-to-Average-Power-Ratio (PAPR) and it means that the working point of linear power amplifiers usually is area where they have low efficiency. The Kahn envelope elimination and restoration (EER) technique is used to enhance efficiency of RF transmitter. Fig. 1 shows block diagram of one EER transmitter. This technique combines a highly efficient, but nonlinear RF PA (class D or class E for example) with a highly efficient envelope amplifier to implement high-efficiency linear RF PA [3].

An envelope amplifier based on a multilevel converter in series with a linear regulator is presented in [4]. It is shown that this solution can reproduce 2 MHz sine wave, with low spectral distortion and providing 50W of instantaneous power. This topology operates at relatively low switching frequency and without additional output filter because the linear regulator filters all the noise and ripple that comes from the multilevel convert.

In this paper two different implementations of this topology are compared regarding its efficiency, complexity, size and possibility of integration.

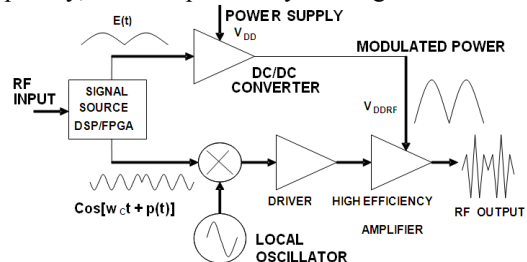

Fig. 1. Block Scheme of Kahn-technique Transmitter

2. ARCHITECTURE OF THE ENVELOPE AMPLIFIER

The topology that is used for the envelope amplifier consists of a multilevel converter in series with a high slew rate linear regulator. The main idea of the solution can be seen in Fig. 2. The multilevel converter has to supply the linear regulator and it has to provide discrete voltage levels that are as close as possible to the output voltage of the envelope amplifier. If this is fulfilled, the power losses on the linear regulator will be minimal,

because they are directly proportional to the difference of its input and output voltage. However, in order to guarantee correct work of the linear regulator, the output voltage of the multilevel converter always has to be higher than the output voltage of the linear regulator. Similar solution, but for lower frequencies and higher power is presented in [5].

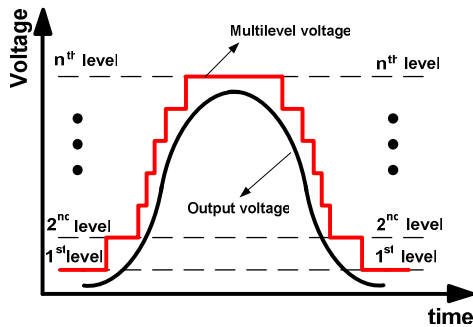

Fig. 2. Time diagrams of the proposed envelope amplifier

There are several possibilities to implement the multilevel converter for this application. The first one, architecture one, is to provide all the voltages that are needed at its output, and then to use a switching network as an analog multiplexer to select each one when it is necessary, Fig. 3. The second solution is to use independent voltage cells that are put in series, and then to generate the output voltage as a combination of its voltages. These cells can be implemented to give just positive voltage (two-level cell, architecture two), or to produce positive and negative voltage (three-level cell, architecture three), Fig. 4.

Due to the independent voltages that have to be produced, it is obvious that it is required to introduce a single-input multiple-outputs stage that will generate all the needed voltages. In the case of the first multilevel solution, the output voltages are the voltage levels that are needed in the system, and they are all referenced to the ground. When the multilevel converter is implemented with two-level and three-level cells, the output voltages should be isolated and referenced to the different grounds. The cell's input voltage does not need to be regulated accurately, because the fine regulation will be done by the linear regulator that is connected in series with the multilevel converter. Additionally, in the case of three-level cell, the cell's input source has to be bidirectional, because, depending on the state of the switches, the source will sink or source the current to the load.

In this paper solutions that employ architectures one and two are compared.

In order to provide fair comparison of two different implementations, both solutions have the same number of levels and the same voltage distribution. The voltage levels are selected in order to maximize overall efficiency and the optimization of the voltage levels is explained in [4].

The envelope amplifiers that have been prototyped have following properties:

- The multilevel converter can reproduce three voltage levels
- The input voltage is 24 V
- The output voltage can be 12 V, 18 V or 24 V

The class E amplifier that is used for transmitter's phase modulation is supplied by the envelope amplifier and it behaves as a resistive load, approximately 12 Ω .

The advantage of this topology is that it provides high dynamics of the output voltage with increased efficiency comparing with linear regulator that is supplied with constant voltage and that its control is very simple and robust. The drawback is that each stage of the system (multiple-output converter, multilevel converter and linear regulator) needs to have very high efficiency, because the total efficiency is the product of individual efficiencies. However, it is still possible to achieve high overall efficiency, as it will be seen later.

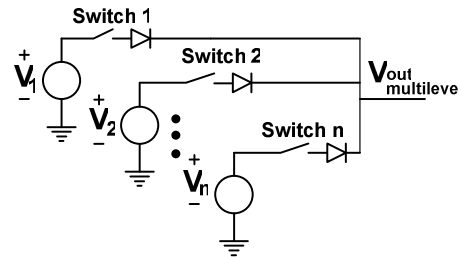

Fig. 3. Multilevel converter realized with independent supplies and analog multiplexer

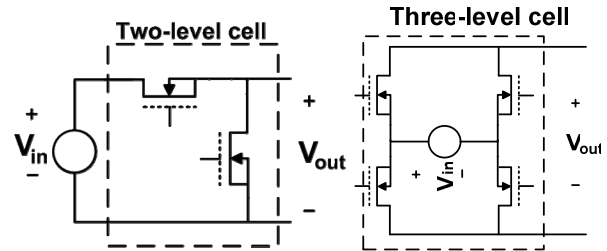

Fig. 4. Voltage cells that could be used as a solution to implement a multilevel converter

3. IMPLEMENTATION OF THE ARCHITECTURE ONE

The multilevel converter for the architecture one is implemented using two converters based on switching capacitor in combination with an analog multiplexer. Both converters have the same topology and divide the input voltage [6], Fig. 5. The first converter is supplied by connecting its input terminals to the ground and 24 V voltage and its 12 V output voltage is referred to the ground. The second converter is supplied by connecting its input terminals between 12 V and 24V. Its output voltage is 6 V, but this voltage is referred to the 12V input, therefore, this output is, actually, 18 V output referring it to the ground, Fig. 6. The 24 V input voltage is directly provided to the analog multiplexer. One of the advantages of this solution is high efficiency that can provide converters based on switching capacitor and that it does not need any huge inductive component, and therefore it can be integrated easily. The disadvantage is that the switching noise or any noise that comes from the input voltage is poorly filtered and this could be a problem for the linear regulator depending on its bandwidth. In order to decrease the propagation of the switching noise to the output and to other system parts, small LC filters are introduced at the outputs of these two converters.

As it is shown in Fig. 3, the analog multiplexer consists of set of switches that are generally realized as a MOSFET in series with a diode. The diode is necessary in order to guarantee that independent voltage sources cannot be short-circuited through MOSFET's parasitic diode. However, in the case of 24 V voltage source only a MOSFET can be used, because there is not any higher voltage source in the system. Similar conclusion can be made in the case of 12 V source where only a diode can be used.

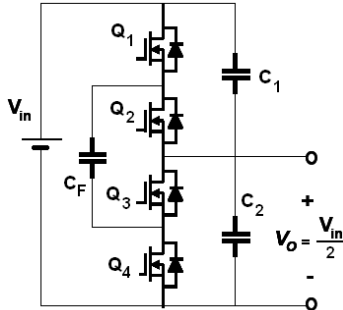

Fig. 5. Voltage divider implemented with switching capacitor converter

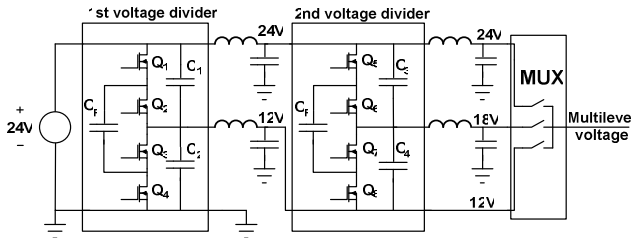

Fig. 6 Block diagram of the multilevel converter for architecture two

4. IMPLEMENTATION OF THE ARCHITECTURE TWO

Fig. 7 shows the block diagram of the implemented envelope amplifier based on architecture two. As it can be seen, a single-input multiple-outputs converter is used to produce several independent voltages that are later combined by using two-level voltage cells.

In the case of the implemented solution in this paper, the single-input multiple-outputs converter is a flyback converter with three outputs. There are two 6 V outputs and one 12 V output. The minimum voltage of the multilevel converter is 12 V and, therefore, only the 6 V outputs are connected to two-level cells.

5. CONTROL OF ENVELOPE AMPLIFIER

In both implementations of the envelope amplifier there can be recognized three stages. The first stage is a single-input multiple-output converter that has to provide independent voltages. The second stage applies summation or multiplexing of the independent voltages in order to produce voltage levels needed by the linear regulator. The last stage is the linear regulator that in its output reproduces the voltage needed by the power amplifier.

The first stage works in open loop when it is implemented with switching capacities. The switching frequency can be very low in order to maximize the efficiency of this stage. However, when a flyback converter is used, the first stage is controlled by a voltage

feedback from one of flyback's outputs, because all the other outputs will follow the controlled one. The bandwidth of this stage does not have to be high; therefore, the switching frequency of the multiple-outputs flyback can be very low in order to increase its efficiency.

The reference signal that should be reproduced is sent to the analog multiplexer or the multilevel converter through the block named "triggering logic" that consists of simple comparator logic. The each voltage level is activated when the reference signal is higher than a certain value (which is different for each voltage level), Fig. 8. Consequently, the output of the multilevel converter will have discrete levels. In the case of the architecture one, the number of levels will depend on the number of the used independent voltage sources and in the case of architecture two on the number of implemented cells. Each cell inside the multilevel converter and each switch inside the analog multiplexer will switch at the maximum frequency of the reference signal. Even more, the dynamic response of the multilevel converter will depend only on the speed of the diodes and MOSFETs that are used inside the switches and cells.

The same reference signal enters in the second stage and in the linear regulator (post regulator). The linear regulator reference has to be synchronized with the output voltage of the multilevel converter in order to guarantee that the system's output voltage (between points C and D, Fig. 7) will be always lower than the output voltage of the multilevel converter (points A and B, Fig. 7) and, therefore, correctly reproduced. Due to the finite time to turn MOSFETs on and off, the output of the multilevel converter is delayed comparing it with the envelope reference, therefore, a delay filter which will compensate this delay is introduced between the reference signal and the linear regulator.

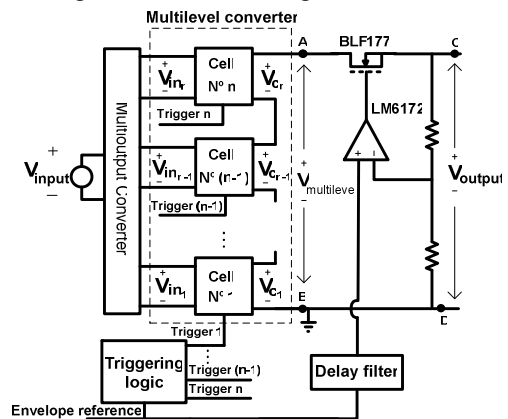

Fig. 7. Block diagram of the implemented architecture two

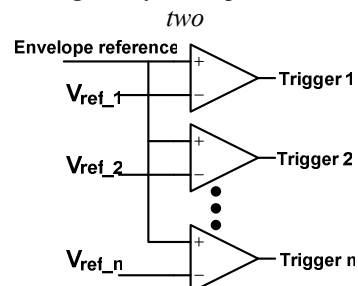

Fig. 8. Comparator logic that is used to control on/off states for each cell/switch of the multilevel converter/analog multiplexer

6. DESIGNED SYSTEM AND EXPERIMENTAL RESULTS

In order to compare two proposed architectures two prototypes of envelope amplifier have been made. The specifications for both prototypes are as follows:

- Variable output voltage from 0 V to 23 V
- The maximum instantaneous power is 50 W
- The maximum frequency of the reference signal is 2 MHz

A. First prototype

The first envelope amplifier prototype consists of:

- Two converters with switching capacitor (first stage)
 - Input voltage is 24 V
 - Three voltage levels are produced (12, 18 and 24 V)
 - Switching frequency is 100 kHz
 - Floating capacitor is 110uF
 - The maximum instantaneous power is, approximately, 50 W
- Analog multiplexer (second stage)
- Linear regulator (post regulator).
 - MOSFET BLF177 as the pass element
 - Operational amplifier LM6172 for the feedback

In Fig. 9 a photograph of the prototype is presented.

Fig. 10 shows the multilevel and system's output voltage in the case of 500kHz and 2MHz sine wave. However, whenever the multilevel converter changes its output voltage there is small glitch in the output voltage. The reason is the finite bandwidth of the linear regulator. Step changes of the multilevel's voltage are composed of very high harmonics that are higher than the regulator's bandwidth. Therefore, the linear regulator is not able to react and stabilize the output voltage very well in these moments. In order to make these transitions "softer", with less high spectral components, the resistance in the gates of MOSFETs that form the analog multiplexer is increased. In this way, the MOSFET's transition time is increased, and therefore the switching loss as well, but, the linear regulator can react better and the glitch in the output voltage is almost removed.

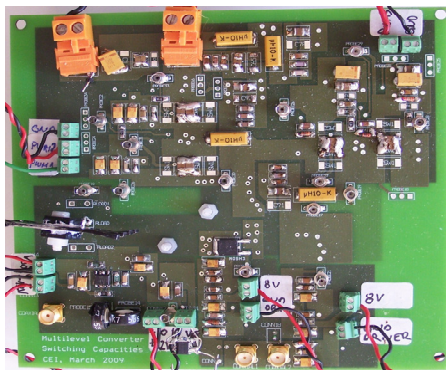

Fig. 9. Photograph of implemented multilevel converter, architecture one

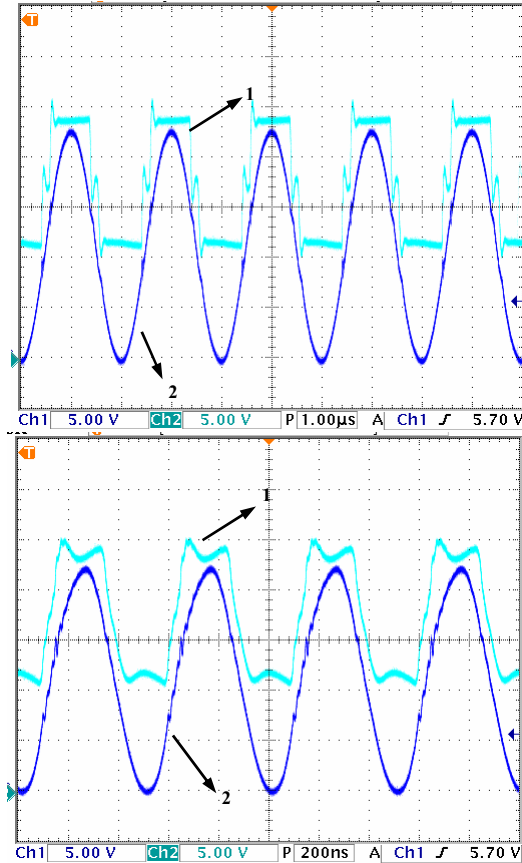

Fig. 10 Waveforms of multilevel (label 1, channel 4) and output voltage (label 2, channel 4) at 500kHz and 2MHz

B. Second prototype

The second prototype's specifications are as follows:

- single-input multiple-outputs flyback (first stage)
 - Input voltage is 24 V
 - Two 6 V outputs and one 12 V output
 - Switching frequency is 50 kHz
 - The maximum instantaneous power is, approximately, 50 W
- multilevel converter with two two-level cells (second stage)
- linear regulator (post regulator, third stage).
 - MOSFET BLF177 as the pass element
 - Operational amplifier LM6172 for the feedback

In Fig. 11 pictures of the second prototype are shown.

Fig. 12 shows the multilevel and system's output voltage in the case of 500 kHz and 2 MHz sine wave. As in the case of the analog multiplexer, it was necessary to increase the transition time of the MOSFETs that are used in the two-level cells in order to avoid glitches in the output voltage.

C. Efficiency measurements

The efficiency of the system for both prototypes is measured for different sine waves and the results are summarized in Table 1. The measured efficiency is compared with theoretical efficiency of the linear regulator supplied by a constant voltage. Both multilevel solutions have better efficiency than linear regulator when signals with small average value are transmitted, and that is mostly the case when the EER technique is applied. The efficiency of the envelope amplifier is

constant (around 43% and 48%, depending on the implementation) when small signals are reproduced, the reason is that only the 12 V cell is active, and there is not any switching losses, only conduction losses, regardless on the frequency of the sine wave. Additionally, the efficiency of the envelope amplifier implemented with switching capacitor is significantly higher than the efficiency of the envelope amplifier that is made by employing a flyback converter.

In Table 2 a comparison regarding the size and weight of the realized envelope amplifier is made.

7. CONCLUSIONS

In this paper two solutions for power supply for EER technique are compared. Both solutions are composed of a multilevel converter that is put in series with a linear regulator. First solution is based on the multilevel converter composed of two switching capacitor converter, and the second solution is based on single-input multiple-output flyback converter. Both prototypes can deliver up to 50W of instantaneous power and reproduce sine wave up to 2MHz. The system's efficiency for both solutions has been measured for the various 2 MHz and 0.5 kHz sine waves and compared with the efficiency of the ideal linear regulator. When the sine wave has small average value (what is usually the case in the case of RF amplifier) both envelope amplifiers have better efficiency up to 20% than linear regulator. It is shown that the architecture based on switching capacitor converters has better efficiency up to 4% and it is smaller and lighter. Additionally, this architecture is lighter, smaller and does not need any big inductive component comparing with flyback converter and it can be integrated easily.

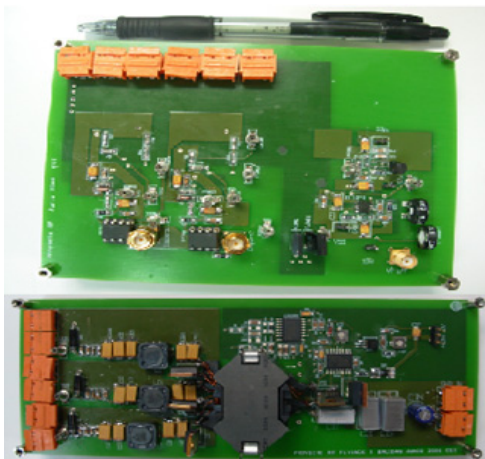

Fig. 11. Photograph of implemented multilevel converter, architecture two

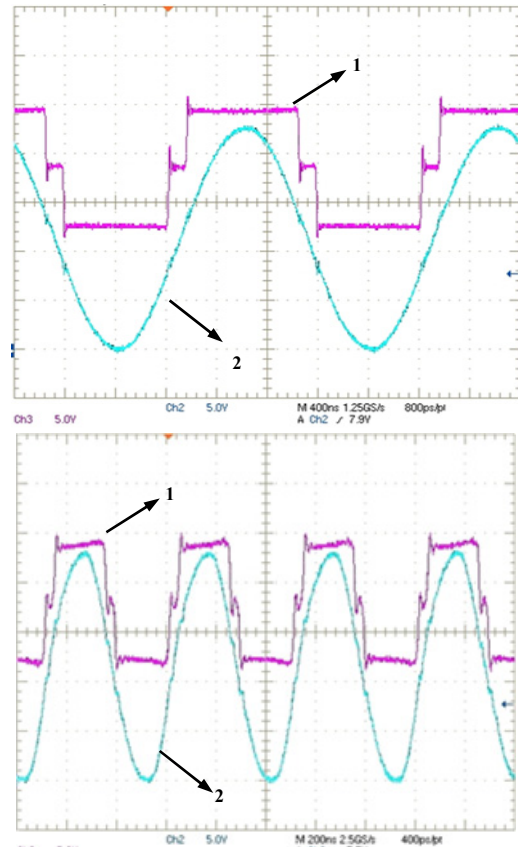

Fig. 12 Waveform of multilevel's output voltage (label 1) and linear regulator's output voltage(label 2) at 500 kHz and 2 MHz

Table 1. Measured efficiency of the implemented envelope amplifiers for different sine waves compared with the theoretical efficiency of an ideal linear regulator supplied by 23 V

$V_{sin}(V)$	Sine wave frequency (MHz)	Measured efficiency of the architecture one	Measured efficiency of the architecture two	Theoretical efficiency of an ideal linear regulator supplied by 23V
0-9	2	48.5%	44.1%	29.3%
5-14	2	59.9%	56.8%	45.9%
0-22.5	2	72.1%	69.8%	73.4%
0-9	0.5	47.9%	43.6%	29.3%
5-14	0.5	61.9%	59.5%	45.9%
0-22.5	0.5	75.7%	71.2%	73.4%

Table 2. Comparison of the implemented envelope amplifiers regarding their size and weight

	Architecture one	Architecture two
Weight[g]	215	420
Size[cm ²]	217.5	297

8. REFERENCES

- [1] S.Roy, "Energy Logic for Telecommunications", white paper for Emerson Network Power, September 2008
- [2] G.Pierre, "Power System Efficiency in Wireless Communication", APEC '06, special presentations
- [3] F.H. Raab, P. Asbeck, S. Cripps, P.B. Kenington, Z.B. Popovic, N. Potheary, J.F. Sevic, N.O. Sokal, "Power Amplifiers and Transmitters for RF and Microwave"
- [4] M.Vasic, O.Garcia, J.A.Oliver, P.Alou, D.Diaz, J.A.Cobos, "Multilevel Power Supply for High Efficiency RF Amplifier", APEC '09, February 2009
- [5] Gong, G., Ertl, H., Kolar, J. W., "A Multi-Cell Cascaded Power Amplifier", APEC '06 2006
- [6] J.Sun, M.Xu, Y.Ying, F.C.Lee, "High Power Density, High Efficiency System Two-stage Power Architecture for Laptop Computers", 37th IEEE Power Electronics Specialists Conference / June 18 - 22, 2006, Jeju, Korea