



POWER LOSSES IN LEADS AND INTERCONNECTIONS OF COAXIAL LINEAR TRANSFORMER

Bogusław Grzesik, Krzysztof Bodzek, Mariusz Stepień
Silesian University of Technology, Faculty of Electrical Engineering, Gliwice, Poland

Abstract: *Proposed high frequency (1MHz) coaxial linear transformer has many advantages: high efficiency (99.26%), high coupling of windings and high power density (2.6 kW). The main drawbacks are relatively high power losses generated in interconnections and leads. The paper contains analysis of these losses that has been done with ANSYS (FEM), basing on 2D and 3D models.*

Key Words: *Modular / tubular / transformer / Ansys / Power loss / Leads*

1. MOTIVATION AND INTRODUCTION

The needs for energy efficient transformers motivates this work, that is continuation of authors' previous work [1]. The paper describes high frequency coaxial linear transformer, cf. section 3, 4 and 9. The transformer belongs to the class of the transformers of highest efficiency. In previous work [1], authors analyzed this transformer using 2D planar FEM model in which interconnections and leads (Fig.3) of the windings were neglected. In order to get the information about the influence of the interconnections and leads of this transformer on its characteristics and overall losses, and efficiency in it. In comparison with transformers described in [2] and [3], proposed transformer have higher coupling between primary and secondary windings and higher efficiency.

The losses in interconnections and leads of the transformer and efficiency are analyzed with FEM software and the latter are measured in the experimental transformer. Analysis was done for planar 2D, 3D and hybrid model called 2D/3D. The losses in interconnections and leads are taken from 3D model while in windings and ferrite core taken from planar 2D transformer. 2D/3D model allows one to carry on analysis of transformer of any length. It is necessary to underline that results from 2D/3D model are close with the ones obtained from 3D.

2. ASSUMPTIONS

The following assumptions has been taken for the analysis.

1. Experimental transformer:
 - turn-to-turn ratio of $k=3/2$ (method of interconnection of elementary transformer is described in [1],
 - windings made of Cu tubes, thickness of its wall is 0.5 mm being equal three times of $\delta=0.167$ mm (double skin penetration depth),
 - water cooling with 20 W of cooling power,
 - length of leads,
 - ferrite core outside of windings (ring: $D_0=9.5$ $D_i=5.4$, $H=5$ mm; Philips Ferroxcube 3F3).
 - Photograph of the experimental transformer is in Fig. 3 (it consists of six such elementary transformers as in Fig. 1.).
2. Operating frequency 1MHz (above 4 MHz the maximum efficiency of transformer decreases, because of large power losses in magnetic core).
3. Supplying from sinusoidal voltage source.
4. Analysis based on Ansys 2D and 3D models.

3. IDEA OF LINEAR TRANSFORMER

Idea of linear transformer is depicted in Fig. 1. Windings are made of copper coaxial pipes. There is an electrical insulation in between the primary and the secondary (e.g. PTFE-polytetrafluoroethylene). The transformer has one-to-one turn ratio. Cross-section of the transformer is shown in Fig. 2.

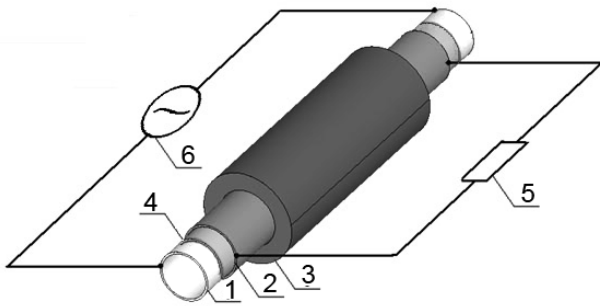

Fig. 1. Idea of linear transformer (elementary)
1-primary winding; 2-secondary winding;
3-ferrite core; 4-insulation; 5-load; 6-voltage supply

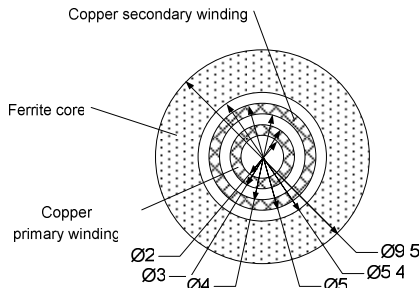

Fig. 2. Cross-section of linear transformer depicted in Fig. 1 and analyzed in this paper

4. ANSYS MODEL

The ANSYS software (FEM) is used to computational analysis of power losses in the leads and interconnections.

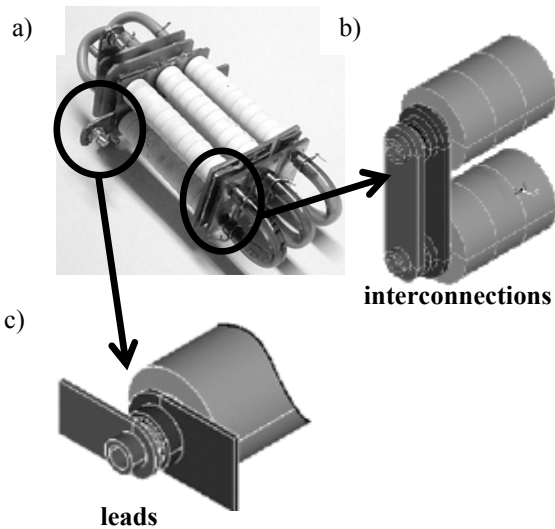

Fig. 3. a) photograph of the experimental transformer 3:2; b) ANSYS model of interconnection; c) ANSYS model of leads;

4.1 Planar 2D model

Planar 2D model was described in [1]. It was used for calculation of power losses and efficiency of the experimental transformer.

4.2 3D model

The power losses in leads were calculated using a short (50mm) 3D model of elementary transformer at the currents 0 to 160 A. (Fig. 4.). 3D model reflects the influence of windings on current distribution in leads. The influence of the leads on power losses in windings can be neglected above 40 mm of the length of the transformers. (Fig. 6 – 3D vs. 2D/3D). Distance between ferrite core and the secondary lead is 1 mm. The same is between primary and secondary leads. The thickness of the lead is 0.5 mm. Interconnections have the same dimension.

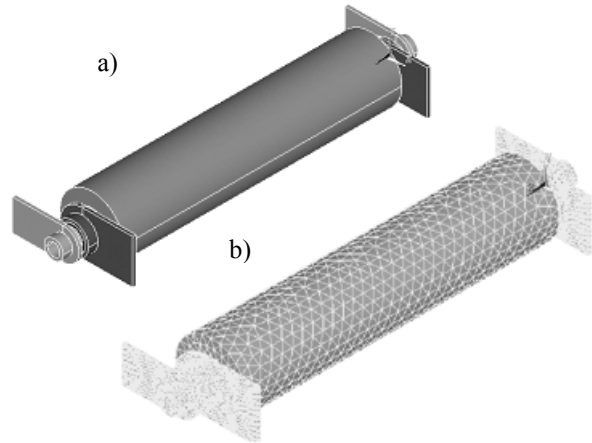

Fig. 4. a) volumes of elementary transformer of 50 mm of length; b) mesh volumes

The power losses in interconnection were calculated using 3D models (Fig. 5) that embraces 3 ferrite rings, of each elementary transformer and interconnection between primary and secondary windings of two elementary transformers.

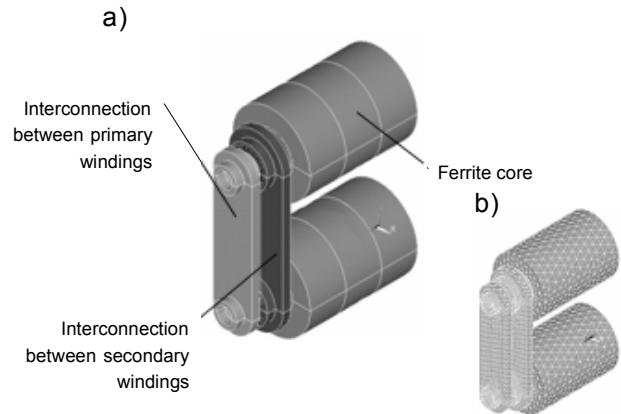

Fig. 5. Model of interconnection between two elementary transformer a) volumes; b) mesh volumes

4.3 Hybrid 2D/3D model

The 50 mm of length of elementary transformer was introduced to limit the demand for system memory. The 3D model of elementary transformer consists of about 350 thousand elements and 60 thousand nodes. This model consumes the almost whole system memory available on 32-bit platform, and single calculation last 17 hours on a T7500 core2duo processor at 2.2 GHz. It was insufficient to calculate of power losses in

interconnections and leads together with losses in windings for transformer longer than 50 mm using the 3D model. Therefore hybrid 2D/3D model was used instead of 3D one.

In the hybrid 2D/3D method the power losses in leads and interconnections were calculated using 3D models (Fig. 4 and 5). The power losses in core, and windings are taken from 2D models.

The difference of power losses obtained with 2D/3D and 3D models is lower than 0.05% (Table 1/4). This small difference can be observed in efficiency (Fig. 6.)

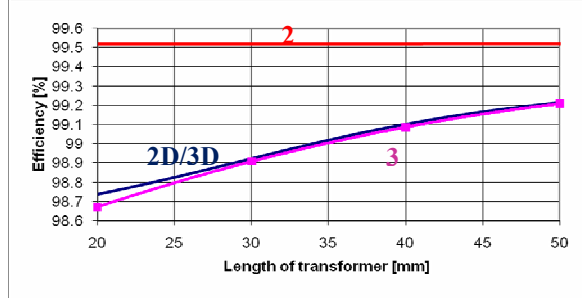

Fig. 6. Total efficiency of elementary transformer

Table 1. Losses obtain with different models

No	Dim.	Variant of transformer	ΔP	Why?
1	2D	Elementary 50 mm of length without leads	ΔP_1	In order to compare 2D, 3D and 2D/3D
2	3D	Elementary 50 mm of length with leads	ΔP_2	
3	2D/3D	Elementary 50 mm of length with leads	ΔP_3	ΔP_{leads} from 3D $\Delta P_{Cu} + \Delta P_{Fe}$ from 2D
4				$(\Delta P_3 - \Delta P_2) / \Delta P_2 \Rightarrow 0.05\%$
5	2D/3D	Transformer 3:2 with leads and interconnections	ΔP_4	ΔP_{leads} from 3D $\Delta P_{interconnections}$ from 3D $\Delta P_{Cu} + \Delta P_{Fe}$ from 2D (for given length)

5. POWER LOSSES IN LEADS AND INTERCONNECTIONS

Power losses in leads and interconnections are not exact square function of total current. It was observed making 3D calculation, and it is so because of irregular distribution of current density (Fig. 7 and 8a).

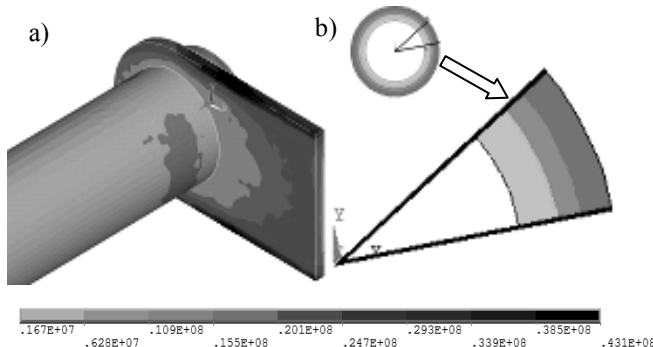

Fig. 8. a) current density in the lead and primary winding - 3D model; b) current density in the winding - 2D model in the middle of 50 mm elementary transformer

One can see there regions with curved surfaces. For example in Fig. 7 and 8a current density is about 43 A/mm² while in the middle of elementary winding is only 15 A/mm² (Fig 8b)

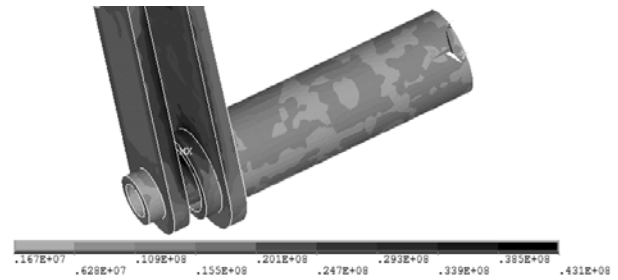

Fig. 7. Current density in interconnection.

The thickness interconnection has an effect on its power losses. Because of irregularity of current density (Fig. 9). It is illustrated in Table 2 where power losses and maximum current density vs. thickness of interconnection at 100 kHz obtained with 3D model. The penetration depth at this frequency is 0.21 mm. Power losses in interconnection is least at thickness equal double skin penetration depth.

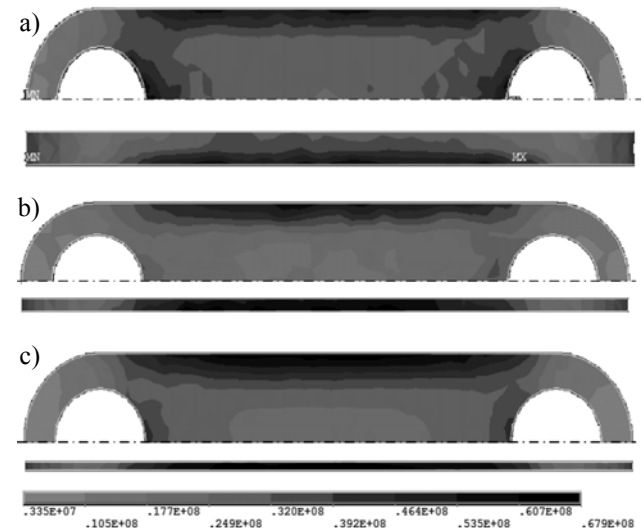

Fig. 9 Current density in interconnection in primitive transformer for thickness: a) 1 mm; b) 0.42 mm; c) 0.1 mm (3D analysis)

Table 2. Power losses and maximum current density vs. thickness of interconnection for 100 kHz

Interconnection thickness D mm	Power losses ΔP mW		Maximum current density J_t A/mm ²	
	primary windings	secondary windings	Primary windings	secondary windings
1	127	80	43	38
0.42	125	78	44	38
0.25	200	116	116	62

The power losses in leads occur due to skin effect (Fig. 10). The highest current density its observed at the edges. To have completed figures power losses in leads were calculated with 3D model. Power losses in pair of leads

of primary winding is $\Delta P_{lp}=122$ mW while in pair of leads of secondary winding is $\Delta P_{ls}=102$ mW. That together is 4.5% of total power losses. Calculation were carry out for elementary transformer 50 mm at frequency $f=100$ kHz and current $I_2=50$ A.

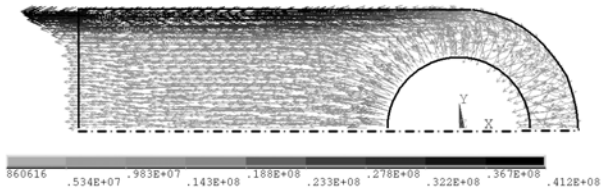

Fig. 10. Vector plot of current density in lead of primary winding of elementary transformer

8. EFFICIENCY VS. LENGTH OF THE TRANSFORMER

Taking power losses in leads and interconnections into consideration one can determine overall efficiency of the primitive transformer (Fig. 11.) as a function of the transformer length. This transformer consists of two elementary transformers. The transformer has 1:1 turn-to-turn ratio.

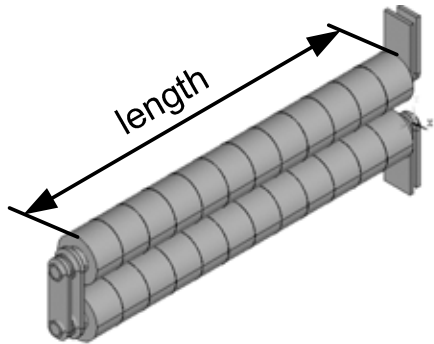

Fig. 11. Primitive transformer

Efficiency vs. length (Fig. 11.) of the transformer was calculated with hybrid 2D/3D model. It should be mentioned that it is maximal efficiency. That is calculated as function $\Delta P=f\{Z(B(U)),R,f\}$ that comes from circuit model of transformer. It could be observed that efficiency is near constant for the length higher then 300 mm.

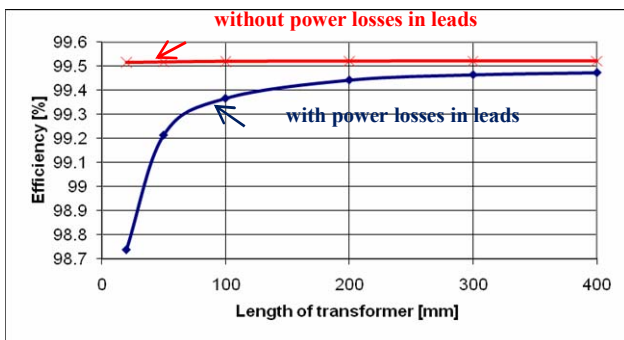

Fig. 12. Efficiency of the primitive transformer (operating at $f=1$ MHz and $I_2 \sim 50$ A)

9. RESULTS COMPARISON FEM VS. MEASUREMENTS

The aim of this section is to compare efficiency of the experimental transformer (see section 2 and Fig. 3a) obtained from 2D, 2D/3D and experiment that is given in Fig. 14. The first step is the calculation of overall losses in leads and interconnections. Using this data the efficiency vs. output power is calculated in the second step.

The overall power losses in leads and interconnections vs. primary current of experimental transformer was calculated and depicted in Fig. 13. It has been done for experimental transformer for which losses of 4 leads and 12 interconnections were summed together.

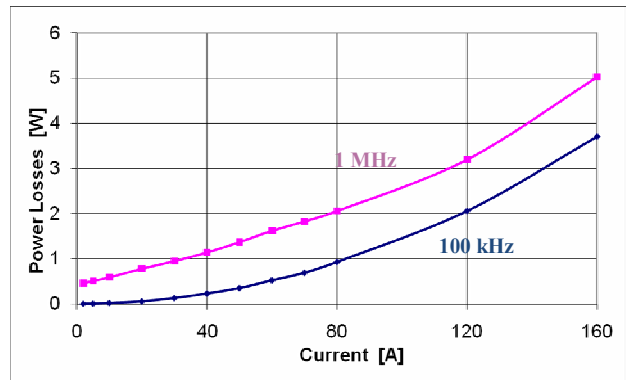

Fig. 13. Overall power losses in leads and interconnections (for input voltage of $100 V_{max}$) of experimental transformer; (4 leads, 12 interconnections)

Taking power losses in leads and interconnection into consideration one can make better model of experimental transformer. The result is depicted in Fig 14.

The output power of the analyzed transformer is 2.6 kW at the efficiency $\sim 99\%$ at the assumption of total cooling power is 20 W.

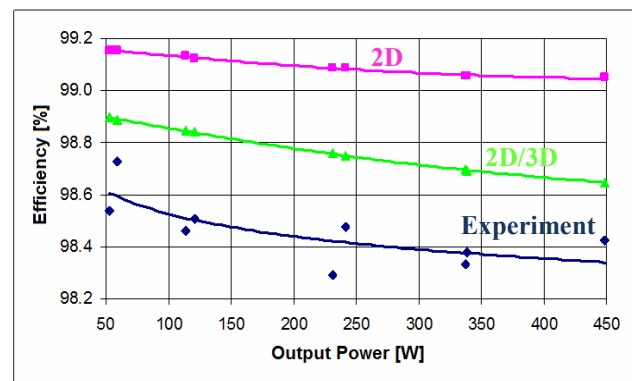

Fig. 14. Efficiency of experimental transformer

The difference between efficiency of 2D and 2D/3D can be explain by losses in leads and interconnection. The discrepancy between efficiency of 2D/3D and experiment [1] comes from e.g. power losses in ferrite core taken for temperature that is different in comparison with temperature in experiment. The inaccuracy of calorimeter gives lower efficiency, which is the second explanation for the discrepancy.

10. INTERCONNECTIONS

Calculation of power losses in experimental transformer has to be carried out using an information about arrangement of interconnections. In order to explain it the further analysis is confined to experimental transformer. The scheme of it is given in Fig. 15. Where two types of n-module is indicated, 1:2 and 1:1. The idea of n-module is given in Fig. 16, where primitive transformers are connected in series by primary windings and in parallel secondary ones.

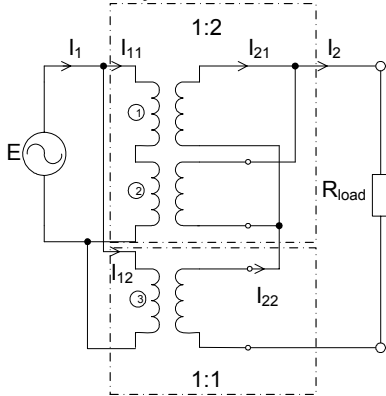

Fig. 15. Scheme of experimental transformer

Using primitive transformers it is possible to build transformer of near any turn-to-turn ratio [1].

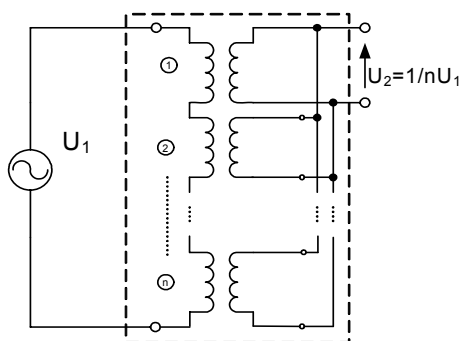

Fig. 16. n-module

It is justified to fabricated interconnection using PCB. Interconnections together with leads are depicted in Fig. 17. It is seen that 12 interconnections and 4 leads is needed for assembly elementary transformer to get complete experimental transformer.

Primary windings are connected exclusively with each other. The same is with the secondary windings. The two double-sided PCBs are needed, No 1 and No 2. The former is for primary leads. The inner side of PCBs connects secondary windings, while its external side connects primary ones.

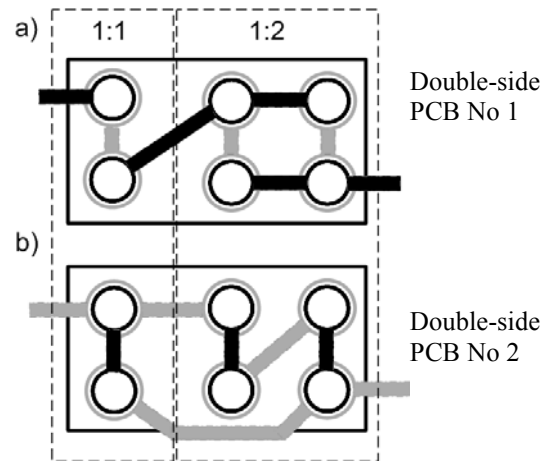

Fig. 17. Method of connection the n-modules a) front side; b) back side

11. CONCLUSIONS

1. Power losses in leads and interconnections are about 5 % of total losses in linear transformer for the transformer of 50 mm of length; the higher length the higher efficiency is obtained.
2. The analysis evidenced that hybrid 2D/3D is acceptable for calculation of losses and efficiency.
3. Power losses in interconnections and leads are least at its thickness equal double skin penetration depth.
4. ANSYS software proves to be suitable tool for power electronics where energy efficient converter are needed.
5. The hybrid 2D/3D model allows to have fine mesh.
6. Continuation of this work is aimed at optimization of the leads and interconnections and for technology of fabrication of the transformer.

12. REFERENCES

- [1] Grzesik B., Bodzek K., Stepień M.: *Modular transformer with any turn-to-turn ratio*, 13th International Symposium on Power Electronics - Ee 2005, Novi Sad, Serbia and Montenegro, Nov. 2-4 , 2005.
- [2] Mark S. Rauls, Donald W. Nowotny.: *Multiturn High-Frequency coaxial winding power transformer*, IEEE transaction of industry application, vol. 31, No 1, January/February 1995.
- [3] Herbert E.: *Design and Application of Matrix Transformers and Symmetrical Converters*, Fifth International High Frequency Power Conversion Conference, Santa Clara, California, 11 May, 1990 .