



ACTIVE POWER FILTER WITH SOFT SWITCHING

Petr Šimoník

VŠB - Technical University of Ostrava, Faculty of Electrical Engineering and Computer Science,
Ostrava, Czech Republic

Abstract: The paper describes used techniques, operation characteristics and develops information of the unconventional soft switched active power filter. The power part is based on progressive IGBT's and high speed voltage and current sensors. The APF is connected in parallel to the AC input of the system, and corrects all loads directly from the AC main. Control unit is based on use of digital signal processor. Used conception brings the savings of electrical energy and better EMC properties in comparison with common kinds of APF. The active power filter can be used for suppression of line current harmonics at AC main.

Key Words: Active Filter, Harmonics, Harmonic Distortion, Resonant Converter, Resonant DC Link, Soft Switching, ZVS Converter

1. INTRODUCTION

The usage of power electronics (switch mode power supplies, adjustable speed drives, and so on) and also the usage of modern and new-fashioned electronic devices has been increasing rapidly on the all world. Modern and new-fashioned devices impose nonlinear loads to the AC main that draw reactive and harmonics current in addition to active current. The reactive and harmonics current lead to low power factor, low efficiency, harmful electromagnetic interference to neighborhood appliance.

As an alternative parallel harmonics correction technique can be use parallel active power filter with resonant DC-link that will be describe in this paper. This parallel active power filter is a device that is connected in parallel to compensated devices and cancels the reactive and harmonics currents from a group of these nonlinear loads so that the resulting total current drawn from the AC main is sinusoidal. The validity of the design methodology is confirmed by use of PSpice computer simulation and by real site testing on the practical realized model of parallel active power filter with soft switching.

Power quality problems are common in most commercial, industrial and utility networks. Resulting problems from current harmonics can be varied, but typically relate to performance, safety and overheating. Power supply system polluted by current harmonics can lead to – over-voltage/current in the power supply system, over-heating in distribution system due to skin

effect, iron losses in transformers, malfunction of automatic control system, damages to capacitor due to resonance, interference in telecommunication systems, voltage distortion and lagging in power factor, and others. However, a flexible and versatile solution to power quality problems is offered by active power filters.

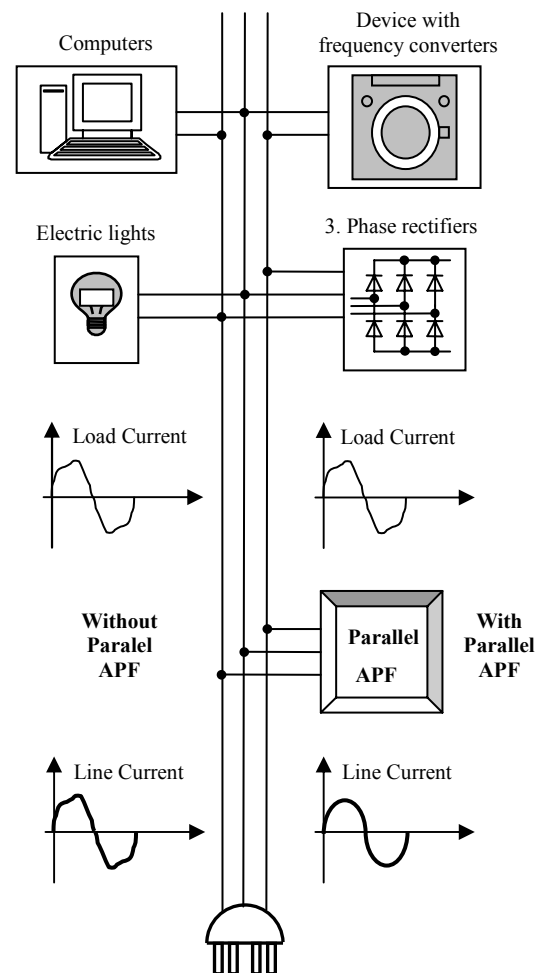

Fig. 1. Block diagram of devices connection

2. FILTER DESCRIPTIONS, POWER PART

This work describes an implementation of parallel active power filter (PAPF) aimed at correcting current harmonics at power supply system. PAPF compensates

current harmonics by injecting equal, but opposite harmonic compensating current. This principle is applicable to any type of load considered a harmonics source.

PAPF is normally implemented with PWM voltage source inverters. In this case the PAPF using converter with resonant DC-link operates as a voltage pulse source, so current is enforced by resonant voltage pulses. Typical controls of PAPF are linear current control, digital deadbeat control, and hysteresis control. However, most methods for obtain right control require high-speed digital signal processor system with fast A/D. In this type of applications is used the special hysteresis control because the converter has resonant DC-link. Resonant circuit is connected between the DC energy store and the power switches of converter's bridge (as shown in Fig. 2).

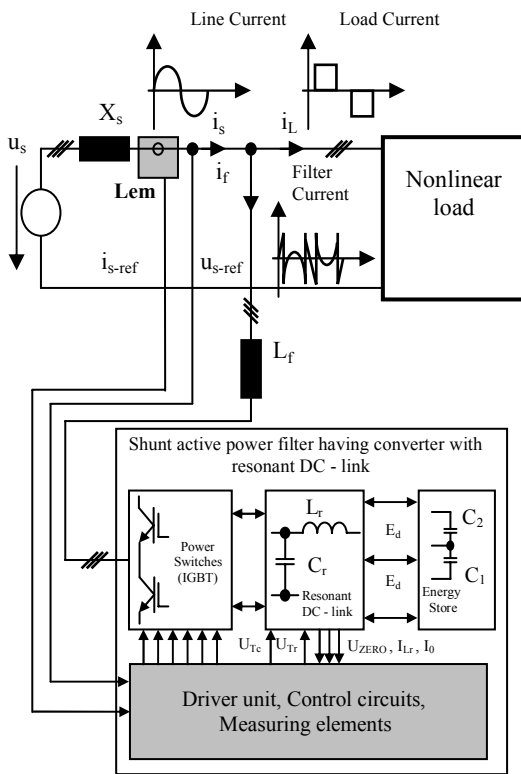

Fig. 2. Block diagram of the power structure and connection with AC main.

The disadvantages of classical hard switched converter (for example the switches are subjected to a high-voltage stress, and the switching power losses of a converter increases linearly with the switching frequency) are eliminated or minimized, because the power switches are turned “on” and “off” when the voltage become zero. The current sensors (Lem sensor, shown in Fig. 2) of PAPF monitor the line current in real time and process the measured harmonics as digital signals for control system with DSP.

The output of the power switches (IGBTs) through line reactors (L_f , shown in Fig. 2) inject harmonic currents with an exactly opposite phase to those that are to be filtered. The net effect is an elimination of the

harmonics and a clean sine wave as seen by the feeding transformer.

3. RESONANT DC-LINK AND DSP CONTROL UNIT

The resonant DC-link has implemented a limit voltage circuit, so called the active clamp circuit. An active clamp circuits as shown in Fig. 3 can limit the link voltage which is shown in Fig. 5 (waveforms of resonant DC-link).

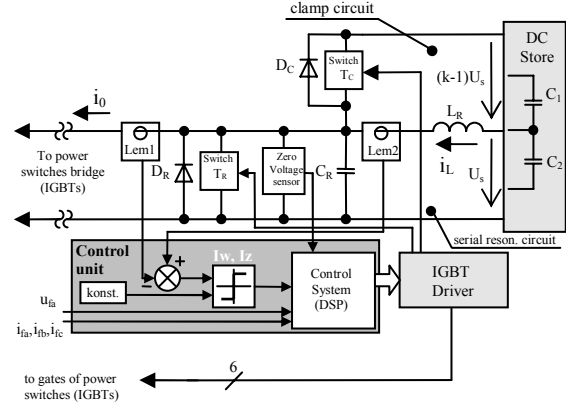

Fig. 3. Used circuit connections of resonant DC link inside the active filter converter structure.

Voltage waveform of resonant DC-link on the Fig. 5 is divided by 10 for better visualization. Without an active clamp circuit are peaks of voltage resonant pulse slightly greater than twice the DC input voltage. The clamp factor k is related to the tank period T_k and resonant frequency $\omega_0 = \sqrt{LC}$ by

$$\frac{f_0}{f_k} = T_k \omega_0 = 2 \left[\cos^{-1}(1-k) + \frac{\sqrt{k(2-k)}}{k-1} \right] \quad (1)$$

That is for fixed value of k , T_k can be determined for a given resonant circuit of the filter's converter. For the value $k = 1.5$ is $T_k = 7.65 \sqrt{LC}$.

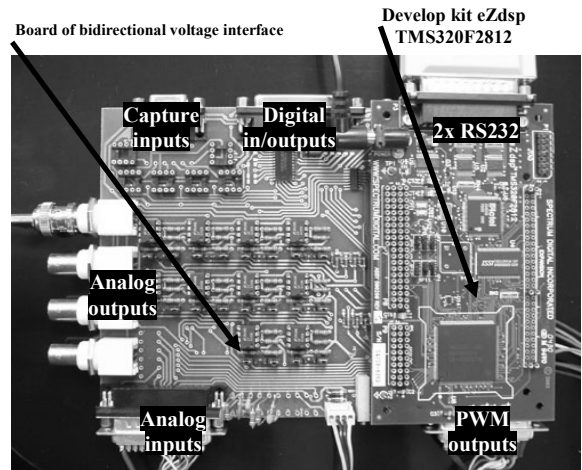

Fig. 4. Control unit based on DSP TMS320F2812

The control unit (which can be seen in the Fig. 4) was designed and executed for the use of powerful microprocessor system based on the Texas Instruments Digital Signal Processor TMS320F2812. Generation of TMS320C28x™ digital signal controllers are the industry's first 32-bit DSP-based controllers with on-board Flash memory and performance up to 150 MIPS. Developed control unit was design as universal control unit and can be used also for other types of converters (in the lab was implemented and tested with Three Level Inverter, Pulse Rectifier and so on). However primary meaning of use should be for soft switched converter which requires high-efficiency control system.

System action is divided to both fast algorithm for control of resonant oscillation in resonant DC-link (as waveforms as is shown at the bottom of Fig. 5) and compensating algorithm of own power active filter and own utility routines.

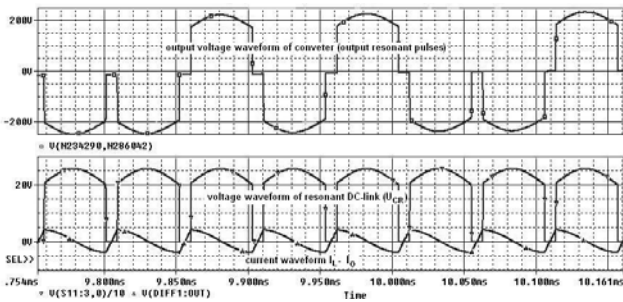

Fig. 5. Voltage and current waveforms of resonant DC-link, output voltage of the converter.

4. COMPUTER SIMULATION RESULTS

The following experimental results were acquired by PSpice simulation model.

Fig. 6 shows the simulation waveforms of PAPP with soft switched converter (having resonant DC-link). The upper trace is current draw of the proposed PAPP (current is injected to the power supply line by the filter). The second trace is line current compensated by proposed PAPP. The third trace is the input current of device with non-linear load (harmonics: $I_1=1A$; $I_3=0,2A$; $I_9=0,2A$).

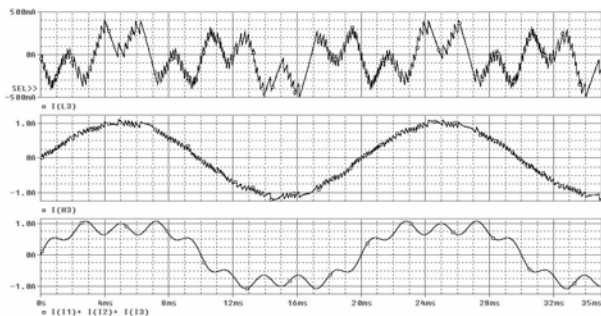

Fig. 6. Current waveforms of simulated PAPP.

Other simulation waveforms of PAPP having soft switched converter shows Fig. 7. The upper trace is the required value of line current. The second trace is the input current of device with non-linear load (harmonics: $I_1=1A$; $I_3=0,2A$; $I_6=0,1A$). The third trace is line current compensated by proposed PAPP.

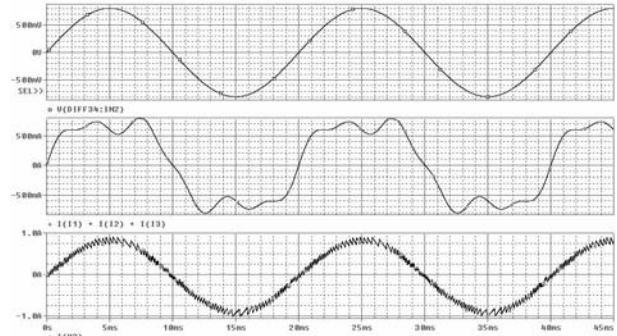

Fig. 7. Current waveforms of simulated PAPP.

Next simulation waveforms of PAPP show Fig. 8. There are three phase waveforms. The upper traces show an input current of device with non-linear load and a line current (the sinusoidal one) compensated by proposed PAPP in the phase "U". The second traces show an input current of device with non-linear load and a line current (the sinusoidal one) compensated by proposed PAPP in the phase "V". The third traces show an input current of device with non-linear load and a line current in the phase "W".

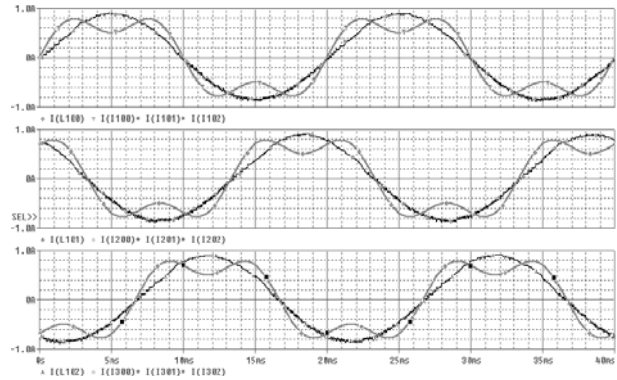

Fig. 8. Three phase simulation waveforms (phase "U", phase "V", phase "W") of PAPP with soft switched converter.

5. MEASURING RESULTS, REAL SAMPLE

Following pictures show practical realization results. In the lab was designed and realized laboratory model of parallel active power filter having resonant converter which shows Fig.9.

The testing was separated into 3 stages. In 1st stage was tested the control unit (Fig. 4) and FFT (Fast Fourier Transformation) computing algorithms. In 2nd stage was tested just resonant converter that was later implanted in PAPP structure and in last stage was tested final behavior of completed PAPP. On Fig. 9 you could see the measuring stand with new laboratory sample of PAPP.

Fig. 10 shows 1st stage testing results. All waveforms are inside signals of the control unit. The upper trace is input current draw i_{La} of device with non-linear load (load consist of resistor $R = 20 \Omega$ and inductor $L = 60 \text{ mH}$). The second trace is the computed 1st (fundamental) harmonic (required value) of line current. The third trace is computed line angle ϕ_1 . The waveforms are right computing results of FFT block (Fast Fourier Transformation).

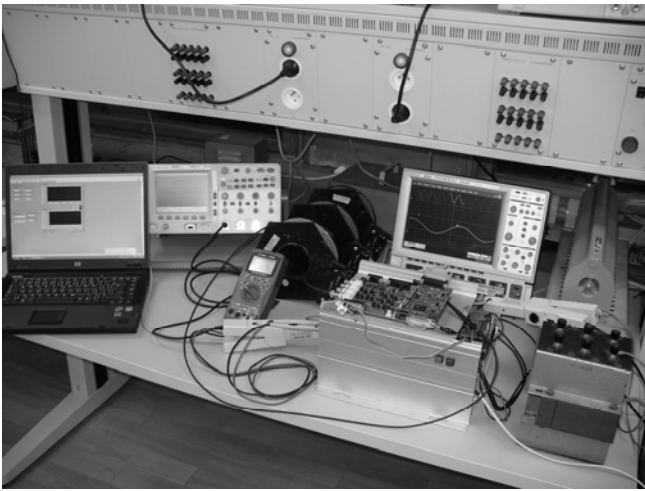

Fig. 9. Measuring stand with laboratory sample of PAF.

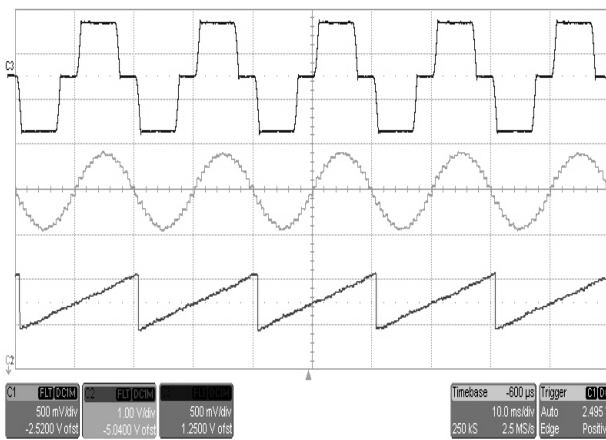

Fig. 10. Calculated data – control signals of practical realized control unit.

Fig. 11 and Fig. 12 shows 2nd stage testing results. All waveforms are signals measured in the structure of applied soft switched converter (new type of converter with resonant DC-link as shows Fig. 3).

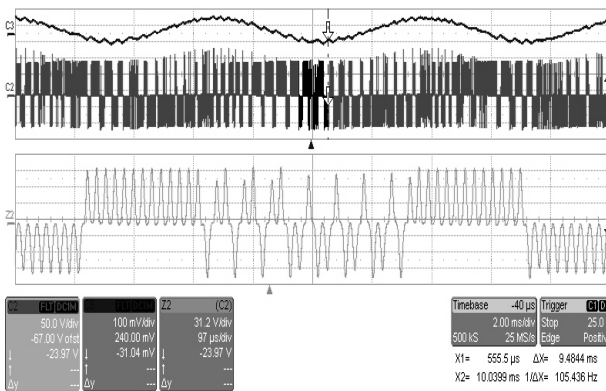

Fig. 11. Output waveforms of applied converter with resonant DC-link.

The upper trace of oscilloscope screen from Fig. 11 is output current draw of converter with resonant DC-link which was working as alone device (load consist of resistor $R = 10 \Omega$ and inductor $L = 100 \text{ mH}$). The second trace is output voltage waveform of the converter and the third trace is detail (ZOOM) of out voltage.

Fig. 12 shows the waveforms confirming the right behavior of practical realized resonant DC-link in case of activated clamp circuit. The upper trace shows DC-link voltage waveforms where we can see right behavior of clamp circuit. Other trace shows waveform of DC-link differential current $I_L - I_0$. Next two trace shows switching of “resonant” transistor T_R and clamp transistor T_C . Below is mentioned detail (ZOOM) of DC-link voltage and DC-link differential current $I_L - I_0$.

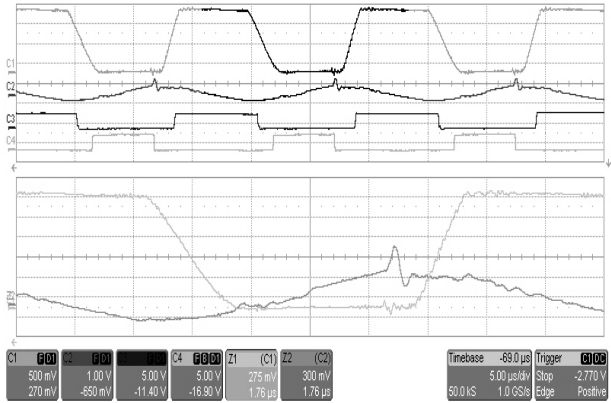

Fig. 12. Resonant DC-link waveforms, main part of practical realized soft switched converter.

In our case (appliance of soft switched converter) was necessary to evaluate performances of a new hysteresis current control strategy for autonomous three phase parallel active filter in harmonic currents elimination. Hysteresis control strategy is based on currents errors and their derivatives calculation each time the zero voltage vector is set at the AC side of the inverter of the active filter.

Fig. 13 and Fig. 14 show last stage testing results. The first trace in Fig. 13 is the input current of device with non-linear load (non-linear load: 3. phase non-controlled rectifier loaded by resistor $R = 20 \Omega$ and inductor $L = 60 \text{ mH}$). The second trace is output current draw of the proposed PAF (current is injected to the power supply line by PAF). The second trace is line current compensated by proposed PAF.

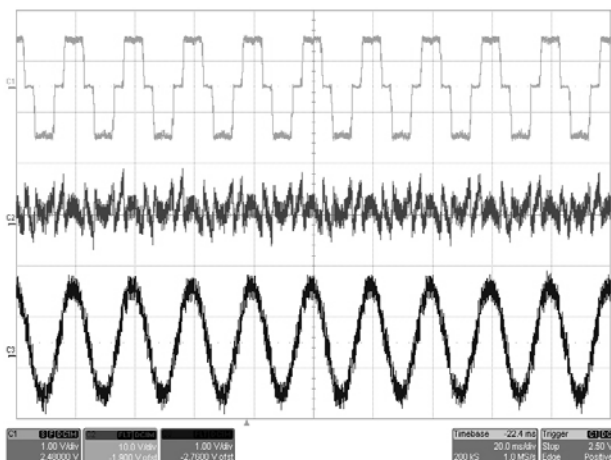

Fig. 13. Measured waveforms show right behavior of realized PAF with soft switched converter.

Fig. 14 shows current waveforms in case of load change (from 0 % to 100%). There you can see the right

and quick adaptation. The first draw in this figure is the input current of device with non-linear load (non-linear load: 3. phase non-controlled rectifier loaded by resistor $R = 20 \Omega$ and inductor $L = 60 \text{ mH}$).

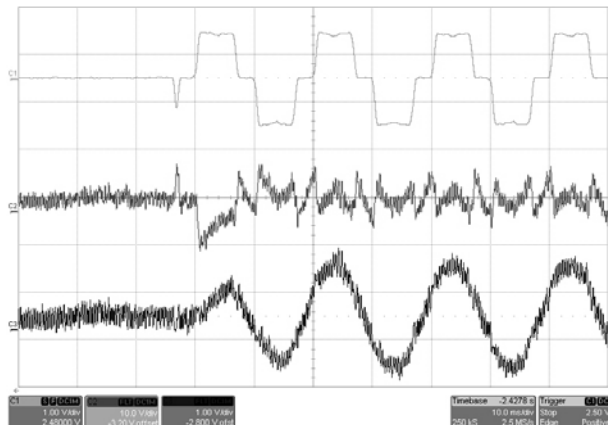

Fig. 14. Measured waveforms show right behavior of realized PAPF with soft switched converter.

The second trace is output current draw of the proposed PAPF (current is injected to the power supply line by PAPF) and last trace is line current compensated by proposed PAPF.

6. CONCLUSION

Active filters have wide application for controlling harmonic currents from nonlinear loads. The device and techniques described in the paper show the possible way to correct current harmonics at power supply system by the new type of parallel active power filter. The operation principles of parallel active power filter with resonant converter have been presented and analyzed in this paper.

The simulation results proved the viability of using resonant circuits (resonant DC-link) for implementation into the structure of parallel active power filters. The simulation circuits were designed as a simplified model. However, for calculation of simulative diagram is needed high – powered computer.

Practical realization was based on simulation results, which are presented in this paper. Presented results confirm right behavior of developed PAPF working as soft switching device (in mode of Zero Voltage Switching). This conception brings the advantages of resonant converters. Such as savings of electrical energy (power switches are turned-on and turned-off when the voltage becomes zero) and much better electromagnetic interference properties.

ACKNOWLEDGEMENT

The project is supported by Grant Agency of Czech Republic (GAČR), project No. 102/09/P665, for which author express their sincere gratitude.

REFERENCES

- [1] Brandstetter, P.: *Research of Active Power Filters*, final research report of project GA CR 102/99/0193, VŠB-TU Ostrava, 2001, 74 p.
- [2] Brooks, T.: *Active Power Filters Provide a Cost-effective and Flexible Solution for System Harmonics Control*, NASA Tech Briefs, Taiyo Yuden, USA, 2004.
- [3] Dudřík, J.: *High-Frequency Soft-Switching DC-DC Power Converters*, Proc. of the II. Internal Scientific Conference of the Faculty of Electrical Engineering and Informatics, pp.45-46, Košice, Slovakia, 2001.
- [4] Chlebis, P.: *Semiconductor Converters with Soft Switching*, monograph, VSB-TU Ostrava, 2004, ISBN 80-248-0643-6.
- [5] Chlebis, P., Dudek, J.: *Comparison of Power Losses and Quality of Output Voltage from Different Types of Inverters*. In 35th Annual IEEE Power Electronics Specialists Conference, Aachen, Germany, 2004, VOLS 1-6, pp. 3120-3126, ISBN 0-7803-8399-0.
- [6] Kazimierczuk, M., K., Czarkowski, D., *Resonant Power Converters*, Wiley – Interscience publication, 2nd Ed., USA, 1995, ISBN 0-471-04706-6.
- [7] Qiao, C., Jin, T., Smedley, K., M.: *Unified Constant-frequency Integration Control of Three-phase Active-Power-Filter with Vector Operation*, IEEE Power Electronics Specialists Conference, USA, 2001.
- [8] Šimoník, P.: *Suppression of Line Current Harmonics by Active Power Filter Having Converter with Resonant DC – link*, OWD 2004, Gliwice, Poland, 2004, ISBN 83-915991-8-3.

THE AUTHOR

Ing. Petr Šimoník, Ph.D.: was born in Uherske Hradiste, Czech Republic, in 1978. He received the MSc. EE. degree (2002) and the Ph.D. degree (2006) at Department of Power Electronics and Electrical drives, VSB - Technical University of Ostrava. At present as member of Department of Electronics his current activity deals with Active power filters with microprocessor control. Also he is deeply orientated into the branch of Automotive electronics.