



POWER QUALITY MEASUREMENT IN A MODERN HOTEL COMPLEX

Velimir Strugar, Vladimir Katić*

Montenegrin Electric Enterprise-Nikšić, FU Distribution-Podgorica, Republic of Montenegro

*University of Novi Sad, Faculty of Technical Sciences, Novi Sad, Republic of Serbia

Abstract: *The paper presents the analysis of power quality characteristics at the 10 kV grids supplying a modern hotel complex in Montenegrin Adriatic coast. The consumer is characterized with different type of loads, of which some are with highly nonlinear characteristic. For example, smart rooms, lift drives, modern equipment for hotel kitchen, public electric lighting, audio, video and TV devices, etc. Such loads in the hotel complex may be source of negative effects regarding power quality at MV public distribution network (10 kV and 35 kV). In the first part of the paper, results of harmonic measurement at a 35/10 kV substation are presented. The measurements lasted one week in real operating conditions (in accordance with EN 50160). The results were the basis for developing a simulation model. The measurement results were analyzed and compared with simulation ones. Application of harmonic filter is simulated. Filter effects on harmonic level is calculated and discussed using simulation results.*

Key words: *modern hotel complex, harmonics, THDU, THDI, computer simulation*

1. INTRODUCTION

Today, power quality problems are on the top of interests of contemporary scientific and expert authorities, dealing with electrical engineering, especially electrical power transmission and distribution networks. One of the most common problems is the appearance of harmonic voltages and currents, which are consequence of different operating regimes of connected nonlinear consumers [1]. The impact of individual consumers has been more or less determined and is known in principle. However, the effects of a large number of the similar or different consumers connected on the same PCC (Point of Common Coupling) in the distribution network (low or medium voltage), with their very different operating characteristics and very stochastic moment of access to the network, is always complicate to determine and often represent a unique

case. Long term monitoring and measurements are applied for harmonic or other power quality parameters analysis, together with specialized simulation software.

In this paper, power quality analysis of a modern hotel complex on the Montenegrin Adriatic coast is presented. Objectives of measurement are determined by the fact that in modern hotels a huge of number of nonlinear loads are applied (large number of audio and video devices, public lighting and elevators, kitchen facility, air conditioning and other non-linear loads). Main objective of measurement is recording of current and voltage waveforms and performing their harmonic analysis. These results are very important for estimation of daily diagram of current variation due to operation of such load, especially in step of planning the connection of these objects, as well as prediction of possible irregular situation in distribution network, which may arise due to poor power quality during their operation.

The paper presents the results of harmonic measurements for the hotel complex during one week in full season. To enable analysis of various situations and loads operating condition, which may occur in actual operation, but not during the measurements, a simulation model of the hotel network is developed. Application of harmonic filters to decrease level of harmonic "pollution" is discussed using simulation results.

2. OBJECTIVE MEASUREMENT

Measurements were performed in the period from the 6th up to the 15th July 2009 using modern power quality monitoring equipment and fully in accordance with EU standard EN 50160. The hotel is supplied from 35 kV line over two substations 35/10 kV, which acts as electricity source for hotel complex. Part of available capacity of power transformers in substation 35/10 kV is used by the distribution operator for other consumers connected to 10kV voltage. Figure 1 presents single-pole schema of distribution network showing connection of the hotel complex.

The connection from 10 kV busbar in substation 35/10 kV to feeder in hotel substation 10/0.4 kV is realized with 10 kV cable. This substation has four transformer units of 1 MVA rated power (TR1, TR2, TR3, TR4). Usually, they are connected in pairs – TR1, TR3 and TR2, TR4, so measurements were performed simultaneously at 10 kV PCC, with two quality analyzers Fluke 434. These devices record all relevant parameters, using of values of secondary current and voltage of current and voltage measuring transformers. Due to paper space constraints, results of measurements on the first pair TR1, TR3 will be presented, only.

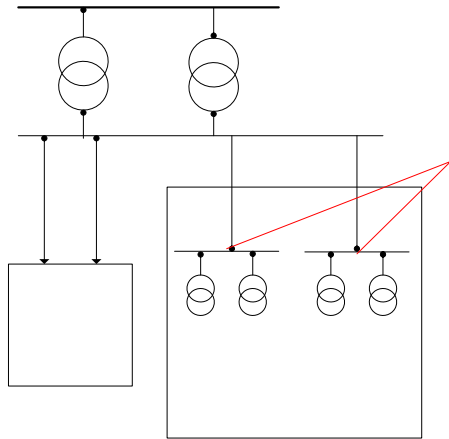

Fig. 1 Single pole schema of the hotel complex connection

Beside considered hotel complex, 10 kV feeder of TS 35/10 kV substation supply a number of other distribution customers (Fig.1) with individually less power (houses, residential buildings, as well as several markets and other retail outlets). There is high probability that possible low power quality parameters, during some operating modes of the hotel complex, will have negative effects on these customers, also. Therefore, measurements results have much wider significance.

3. RESULTS OF MEASUREMENTS

R.m.s. values of current and voltage variation of in all three phases during the measurement period are recorded. Also, variations of active and reactive power were monitored. For recorded values of voltage and current, harmonic analysis is performed calculating individual harmonics (HDUn, HDIn), as well as total harmonic distortion (THDU, THDI). Figures 2 and 3 show spectrum of voltage and current harmonics in the measurement period, respectively, while Figures 4 and 5 show time variation of THD and some individual harmonic values.

Results show that in general case, the hotel activity does not have permanent negative effects on the network and cannot cause harmonic disturbances in higher level than that stipulated in EN 50160. Such conclusion is result of harmonics and THD values shown on Figures 2 and 3. All harmonics values and total harmonic distortion of voltage and current are within limits stipulated in standards.

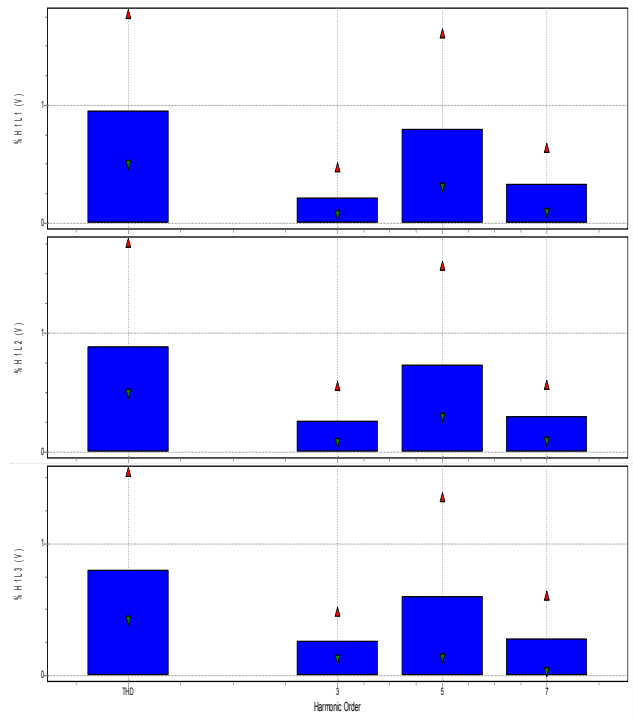

Fig. 2 THDU and voltage harmonics- HDU_3 , HDU_5 , HDU_7 (Line 1-top, Line 2-middle, Line 3-bottom)

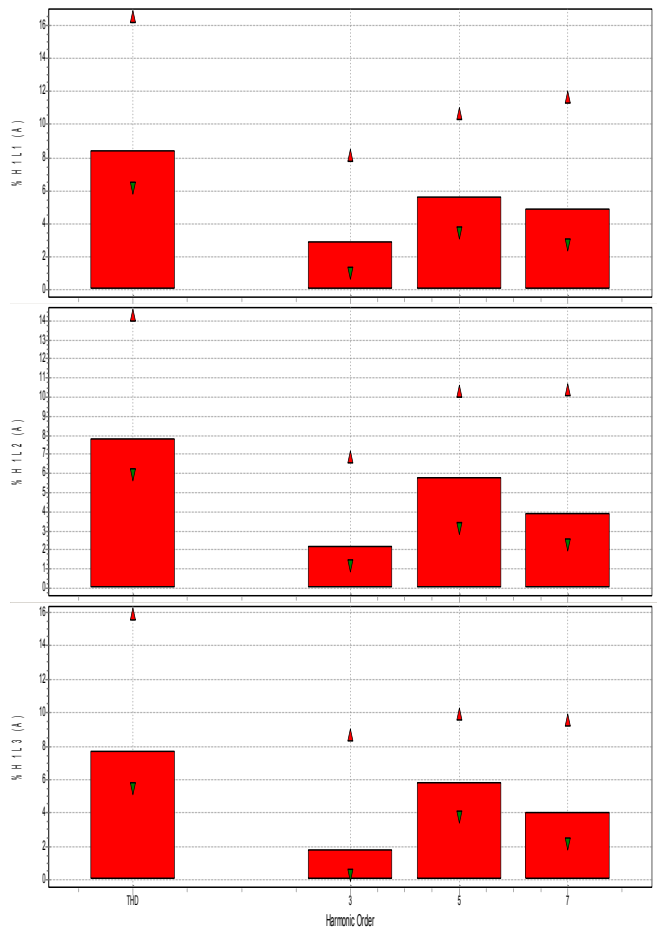

Fig. 3 THDI and current harmonics- HDI_3 , HDI_5 , HDI_7 (Line 1-top, Line 2-middle, Line 3-bottom)

However, the default state of change short-circuit current on 10kV grid in substation in the hotel complex,

It may further affect the variance of parameters. It was also apparent relation between the changes in measuring period of the 5th harmonic voltage and current THD, and voltage and current (Fig. 4). It is obvious that dominant effect on THDU has the 5th harmonic. This is the recognizable characteristics of the distribution system.

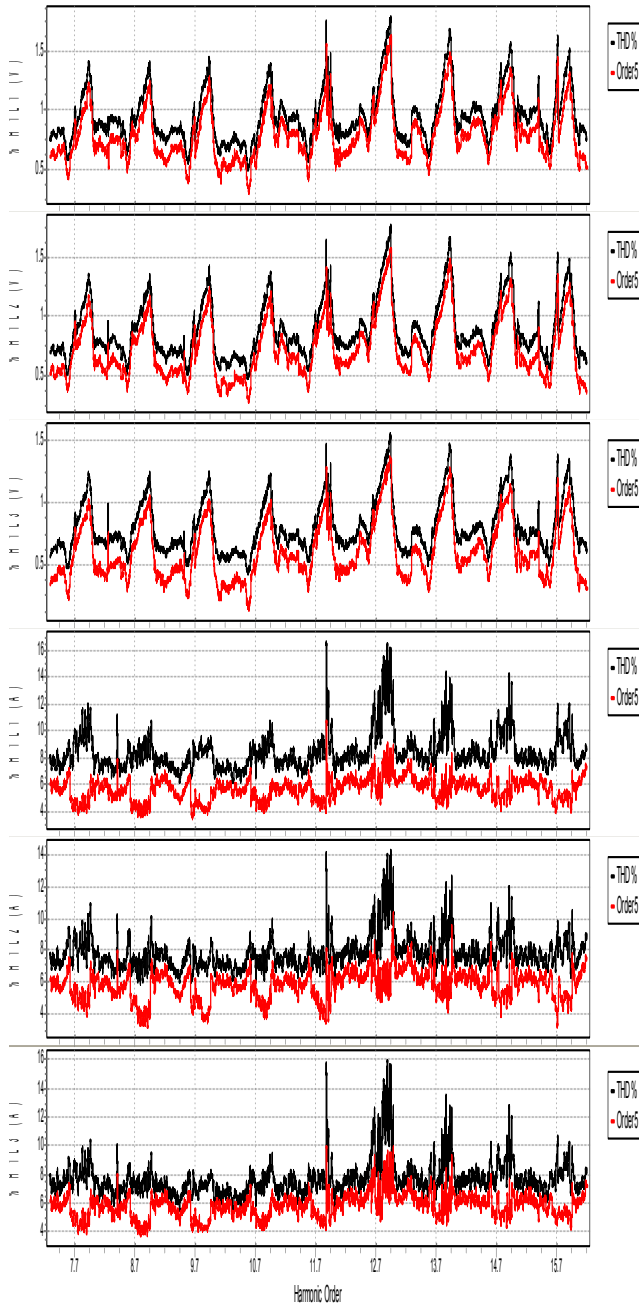

Fig. 4 Top3 graphics: THDU (black line) and HDU₅ (red line) for three phases (L1, L2, L3); Bottom 3 graphics: THDI (black line) and HDI₅ (red line) for three phases (L1, L2, L3).

Although the value THDU is in accordance with the limits defined in the standards [1], and not surpassed 5%, the THDI in some phases is greater than limits. Namely, for 10 kV grid in consideration, the relationship between maximum current (load) and maximum short circuit current on the buses [9] is

$$20 < I_{sc}/I_L < 50 \quad (1)$$

According (1) and [9] is obviously that all values THDI greater than 8% are problem. This is especially visible in Figure 5, for all days from the July 11, 2009 up to the end of measurement, and especially for July 12, 2009 after midnight, when the values reached level beyond 16%. It is obvious that simultaneous activity of many nonlinear consumers in these hours (air conditioning, audio video equipment, a multitude of electronic devices for entertainment, etc.) contribute to this effect.

4. COMPUTER SIMULATION MODEL

The computer model is based on actual network and power quality parameters, which are known as result of previous measurement [2-9].

Simulation mode of part of the real distribution system, there is specialized application software PSS / VIPER (Power System Simulator / Visual Power Engineering). PSS/VIPER can model any balanced three-phase AC power system for marine, industrial, and small utility-distribution systems.

At the beginning, a simplified model of the system is arranged, with the inclusion of equivalent elements in order to obtain similar situation as in real system. Then, the varying parameters (harmonic filters and sources) required actions noted in the introduction to the system in the state of the greatest degree of stability.

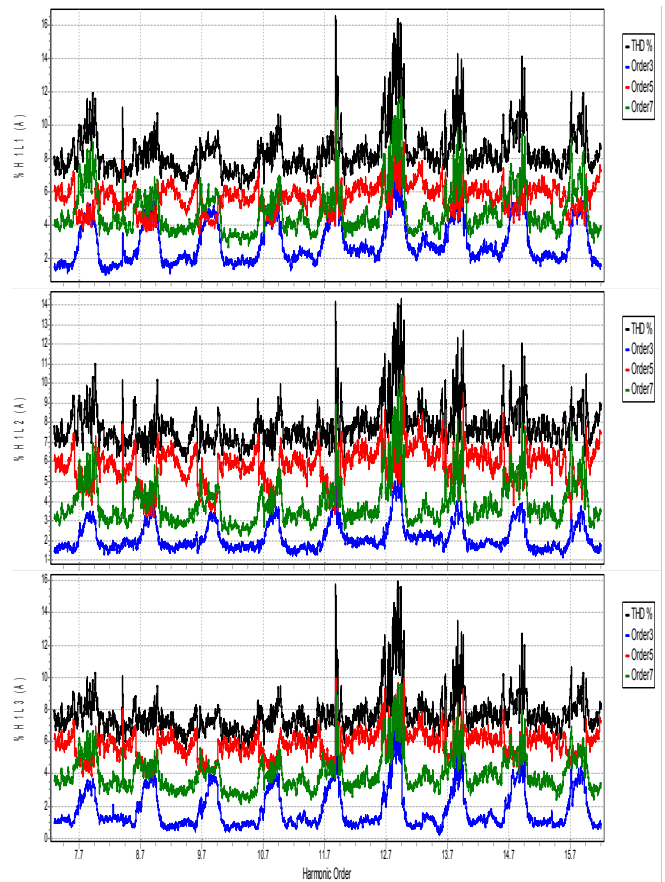

Fig. 5 THDI (black line) and HDI for the 3rd (red), the 5th (green) and the 7th (blue) harmonics in three phases (L1, L2, L3) for the entire interval measurements

Figure 6 and 7 gives an overview of the single-pole scheme of electrical network, which supplies the hotel

complex. The 35 kV line supplies the 35 kV feeder at the substation 35/10 kV. The model for 35 kV source is synchronous generator. Furthermore, 10 kV busbar, as stated earlier, supplies part of the power distribution network. This part of network is presented in simultaneous model as load, similar to the 0.4 kV buses, where the hotel complex presented with characteristic load (Fig.1). Parameterization of model elements or a standard (for the synchronous generator and transformer), are varied in accordance with the measurements (for 10 kV lines and 0.4 kV and the load, as well as harmonic sources).

Table 1 gives the numerical value obtained for the third, the fifth and the seventh harmonic voltage and THDU. Due to consistency, 100 (per unit) must multiply all values in the table. The effect of the filter installation is obvious comparing the data from the table below.

To improve the power quality regarding harmonic levels, a harmonic filter is considered. It is a single tuned filter as on Figure 7. In the computer simulation, installation of harmonic filters at 0.4kV busbar was performed with identical setting for both transformers. Filters locations are shown on Fig.8.

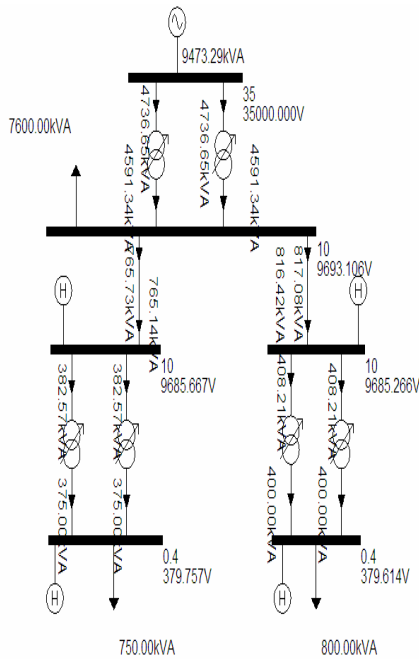

Fig. 6 Single-pole scheme model observed distribution system before the installation of filters

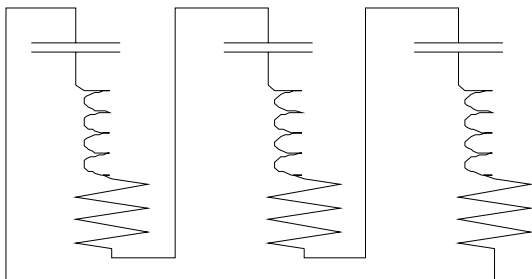

Fig. 7 Tree-pole tuned filter

Table 1. Value of harmonic voltage levels and THDU before the installation of filters

	Busbar	H3 (p.u.)	H5 (p.u.)	H7 (p.u.)	THDU (p.u.)
1	35	0.000	0.001	0.000	0.002
2	10	0.004	0.009	0.006	0.012
3	10	0.005	0.010	0.006	0.013
4	0.4	0.009	0.018	0.009	0.023
5	10	0.006	0.010	0.006	0.013
6	0.4	0.009	0.018	0.013	0.025

Settings of a filter connected in Δ are given in per unit using the following base values of the filter:

$$R = 0.2$$

$$Xc = 2.604$$

$$XI = 0.10416$$

Filter was chosen for the expected size of 1000kVA.

Results of filter application are presented in Table 2 and on Figures 9 and 10. It can be seen that harmonics are significantly mitigated, i.e. that negative effects of non-linear loads in the hotel complex can be lowered by installing of the described harmonic filters at 0.4 kV buses.

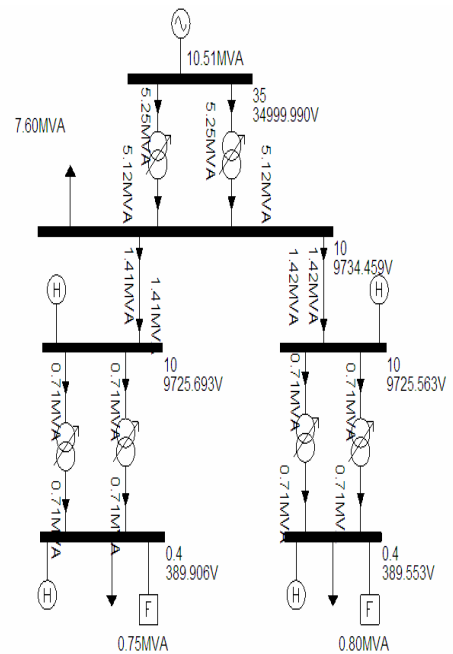

Fig. 8 Single-pole scheme model observed distribution system after the installation of filters

Table 2. Value of harmonic voltage levels and THDU after the installation of filters

	Busbar	H3 (p.u.)	H5 (p.u.)	H7 (p.u.)	THDU (p.u.)
1	35	0.000	0.000	0.000	0.000
2	10	0.000	0.002	0.002	0.003
3	10	0.000	0.002	0.002	0.003
4	0.4	0.004	0.011	0.008	0.015
5	10	0.000	0.002	0.002	0.003
6	0.4	0.004	0.010	0.012	0.016

5. CONCLUSION

In countries with an attractive environment and incomplete developed distribution network, the challenges of modern construction can sometimes be problematic. This is particularly case in building modern hotel complex, smart buildings, modern shopping malls and entertainment centers, especially when it comes to connection of such facilities to the electric power distribution network, as they are, in principal, designed for the standard levels of nonlinearity, described by $\cos\phi$ and its common values.

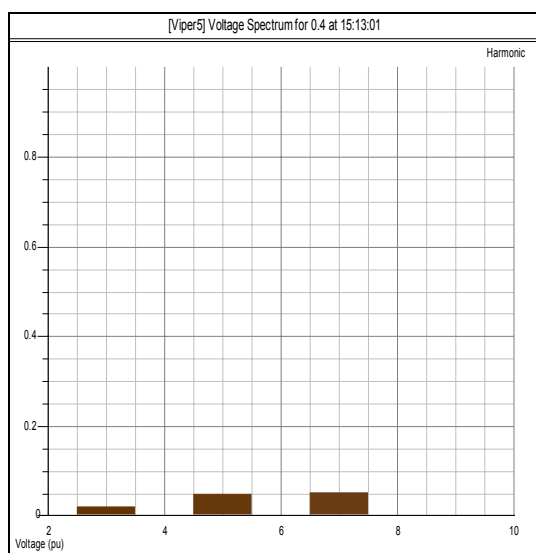

Fig. 9 Harmonic voltage spectrum of models before the installation of filters

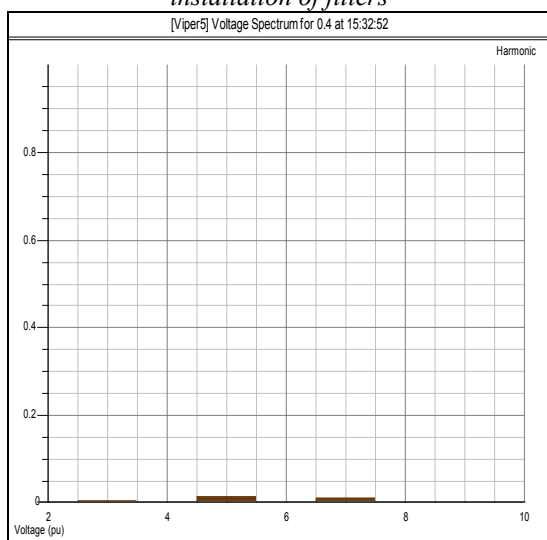

Fig. 10 Harmonic voltage spectrum of models after the installation of filters

Today, the simultaneous operation of many nonlinear devices in modern facilities in consideration, imposes the necessity of new ways of planning of distribution networks, primarily it means the standard model of consumer connection procedure. By using standardized equivalent scheme for typical consumers (hotels, restaurants, shopping center, apartment), it is easy to come to the equivalent scheme of the part of

distribution system, and then, and his planning is not particularly difficult.

In the process of issuing of conditions, that the investor has to fulfill to the end of construction to obtain approval for connection to distribution network, it is necessary to be well-acquainted modes of future consumers.

Therefore, especially importance is the modeling, especially large consumers modeling. Consequences of poor planning when it comes to the quality of delivered electricity and consumers may feel that causes disruption, but also the surrounding consumers who connected on the same point of common access. Who will pay the consequences, and final, must be the focus of attention operator distribution.

6. REFERENCES:

- [1] V.A.Katić: "Electric Power Quality-Harmonics", Monograph, University of Novi Sad-Faculty of Technical Sciences, Edition: Engineering - Monographs, No.6, Novi Sad, 2002, (In Serbian).
- [2] V.Strugar, *Justification of Harmonic Measurements in Network of ED Tivat Regarding Their Effects on Quality of Supplied Electrical Energy*, Workshop on Power Quality – Standards, Measurement and Reliability, Faculty of Electrical Engineering, Podgorica, Montenegro, June 2004, CD ROM (In Serbian).
- [3] V.Strugar, V.A.Katić, Z.Čorba, *Harmonic Measurement in Distribution Network of ED Tivat*, 27th Conference JUKO-CIGRE, Zlatibor, Serbia, May 29th – June 3rd, 2005, Vol. III Group C1-C6, Paper: R C4-05 (In Serbian).
- [4] V.Strugar, V.A.Katić, Z.Čorba, *Effects of Military Shipyard Operation on Electric Power Quality in Public Distribution Network-A Case Study*, PCIM Europe 2005, Nürnberg, June 2005, CD ROM.
- [5] V.Strugar, V.A.Katić, B.Dumnić, D.Milićević, *Influence of single industrial consumer on power quality at the 35 kv grid*, 13th International Symposium on Power Electronics - Ee 2005, Novi Sad, Nov.2-4, 2005, CD ROM.
- [6] V.Strugar, V.A.Katic, *Effects of Some Industrial and Other Plants Operating in Real Distribution System*, Power Systems World, 16th Power Quality & Reliability Conference, Oct. 24-26, 2006, Long Beach, CA, USA, CD ROM.
- [7] V.Strugar, *Power Quality Indices Measurement In Real Distribution Network*, EMD, XVII Int. Conf. on Electromagnetic Disturbances 2007, 19-21 September 2007, Bialistok, Poland, CD ROM
- [8] V.Strugar, V.A.Katic, *Effects of Industrial and Other Consumers on Operation of a Distribution System*, 28th Conf. JUKO CIGRE, Sep. 30 – Oct. 5, 2007, Vr. Banja, Srbija, CD ROM (In Serbian)
- [9] V.Strugar, *Determination of power quality supply level in real public distribution network*, Master Thesis, University of Novi Sad – Faculty of Technical Sciences, Novi Sad, Serbia, Nov. 2005 (In Serbian).