



# DEVELOPMENT AND REALIZATION OF INDUCTIVE PROBE FOR RESISTIVITY MEASUREMENTS IN THE BOREHOLES

Stojan Jaic, Miodrag Brkic, Miloš Živanov, Viktor Dogan  
University of Novi Sad, Faculty of Technical Sciences, Novi Sad, Serbia  
[jaicstojan@yahoo.com](mailto:jaicstojan@yahoo.com)

**Abstract** – During the geophysical researching and measurement inside the soil, in order to collect necessary data, different measuring probes are used. In this paper is described development and realization of inductive probe for measuring the resistance of the boreholes. Inductive probe is designed with coil system which is coupled by induction, therefore electrical contact with the mud or formation is not necessary. This probe can be applied in the boreholes filled with air, gas, fresh mud or oil base mud. With appropriate construction of coils and mutual arrangement the influence of invasion zone (formed during drilling) is significantly minimized. Effects of environment which affect the measurement and mathematical approach that reduces the impact of these effects are analyzed.

**Keywords:** Induction probe, Resistivity, geophysical measurement, Boreholes.

## 1. INTRODUCTION

Focused Induction Logs have proved to be the best method for resistivity measurements in the boreholes. Induction tool is designed to record conductivities deep within the formation, minimizing the effect of the invaded zone.

Induction logs may be used in wells filled with air, fresh mud or oil base mud. The coil system is coupled with the ground by induction, therefore electrical contact with the mud or formation is not necessary. Oil-based drilling muds are extremely resistive and, therefore, cause major problems for the existing 'direct contact'-resistivity tool which need a conductive mud column to provide an electrical connection between electrodes and the formation. Eddy current measurements are considered as a solution to the oil-based mud problem. Commercial induction tools consists of multiple coil arrays designed to optimize vertical resolution and depth of investigation. In practice, each coil can consist of from several to a hundred or more turns, with the exact number of turns determined by design considerations.

## 2. BASIC PRINCIPLE OF OPERATION OF THE INDUCTION LOGGING INSTRUMENT

The high-frequency alternating current, which is maintained at a constant value in the transmitter coil of the induction logging instrument, sets up an electromagnetic field which extends into the formation surrounding the instrument. The periodically changing electromagnetic flux of this field induces secondary currents of the same frequency in the conducting formation surrounding the transmitter coil (Fig 1). In effect, the conductive formation surrounding the coil serves as a single-turn secondary circuit which is inductively coupled to the transmitter coil. The current induced in this secondary field, the formation, flows in the entire volume of the conducting formation surrounding the logging tool. In a completely homogeneous formation these elemental conductive paths are toroidal in shape and have axial symmetry with the borehole. The density of the current induced in each of these elemental paths depends upon the conductivity of the formation within the path. Fig. 1 shows only two of these elemental loops in different positions with respect to the transmitter and receiver coil. An alternating current  $I_1$ , for example, induced in the elemental loop  $a_1$  by the electromagnetic field from the transmitter coil traveling over a path from T to  $a_1$ .

The high-frequency currents which are induced in these elemental toroids of conductive formation produce their own electromagnetic field. These secondary field travel through the formation in the same manner as the primary field. The portion of the field traveling over a path from the elemental loop  $a_1$  to the receiver coil R induces a voltage in the receiver circuit. The full signal developed in the receiver coil is the sum of the voltage contributions of all of the toroidal currents flowing in the formation [1].

The signal induced in receiver coil is phase-shifted by  $90^\circ$  in relation to the eddy current, or about  $180^\circ$  in a relation to the current in a transmitting coil. In practice, the sources of the electromagnetic field used in induction

logging, are coils wound on an insulating mandrel through which alternating currents passing.

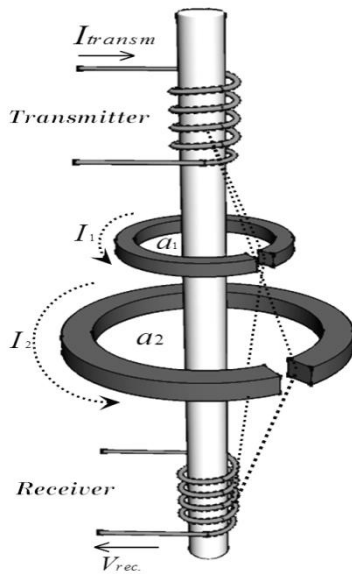

Fig. 1 principle of operation of the induction log [2]

Each coil will consist of several turns, the exact number being set by many engineering considerations, but will cover axially only a few centimeters of the mandrel. [3]. We can also mention, that the probe usually contain multiple coils (multi-coil system). The extra coils are used to focus the signal. Focusing achieves several improvements in signal response:

- Better vertical resolution by stronger suppression of the adjacent bed signals
- Smaller borehole effect, and deeper investigation.

### 3. GEOMETRIC FACTOR THEORY

The geometric factor theory present a method of computing the response of an induction logging coil system. Performance of a coil system has commonly been evaluated on the basis of the integrated radial geometric factor  $G_r$ , and the integrated vertical geometric factor  $G_z$ . The integrated radial geometric factor is used to predict the invasion response of the tool in thick homogeneous formations, while the integrated vertical geometric factor predicts the response of the tool to tin beds. The geometric factor can be defined as 'a dimensionless number for a horizontal loop of homogeneous ground, having a circular shape with its center on the axis of the hole, and whose cross section is a very small square of unit area'. Calculation of the geometric factor  $g$ , depends on its geometric position in the formation in relation to the center of the transmitter-receiver coil spacing.

Figure 2 represents a two-coil induction logging system, consisting of a single transmitter and receiver surrounded by a loop of homogeneous ground.

The voltage at the receiver from a unit ground loop of radius ' $r$ ' and altitude ' $z$ ' with respect to the center of the coil system is given by:

$$V_r = K g \sigma, \quad (1)$$

Where  $K$  is a function of the area of the transmitter and receiver coils, distance between the coils, current in the transmitter, and frequency of the transmitter current.

$g$  is geometric factor which depends on the geometric position of the unit loop as related to the transmitter and receiver coils.  $\sigma$  - conductivity of the ground loop. Thus, if the receiver voltage is known, it's easy to calculate the formation conductivity, or true resistivity  $R_t$  (inversely proportional to the conductivity):

$$R_t = \frac{1}{\sigma}, \quad (2)$$

The radial geometric factor considers the formation as the combination of a large number of cylinders coaxial with the borehole. From the above definition of ' $g$ ', the integrated radial geometric factor  $G_r$ , is the sum of all the ' $g$ ' values for all the area of cross section within a cylinder of radius  $r$ . In a similar manner the integrated vertical geometric factor  $G_v$ , becomes the sum of the ' $g$ ' values for all of the area of cross section above (or below) a horizontal plane at a distance ' $Z$ ', from the center of the tool. The integrated vertical geometric factor increases with vertical distance ' $Z$ ', and must be equal to unity for all space.

Function  $g$  can be expressed either as a function of radial ' $r$ ' and vertical ' $z$ ' distance relative to a plane which passing through 0 (the mid-point of emitter-receiver spacing), perpendicular to the probe axis [4].

$$g = \frac{L}{2} g_0 = \frac{L}{2} \frac{r^3}{\left[r^2 + \left(\frac{L}{2} + z\right)^2\right]^{3/2} \left[r^2 + \left(\frac{L}{2} - z\right)^2\right]^{3/2}}, \quad (3)$$

Where  $L$  is the coil spacing.

At the end, voltage at the receiver from a whole environment can be calculated as:

$$\varepsilon = K \sigma \int_s g ds = K \sigma \int_r dr \int_z dz, \quad (4)$$

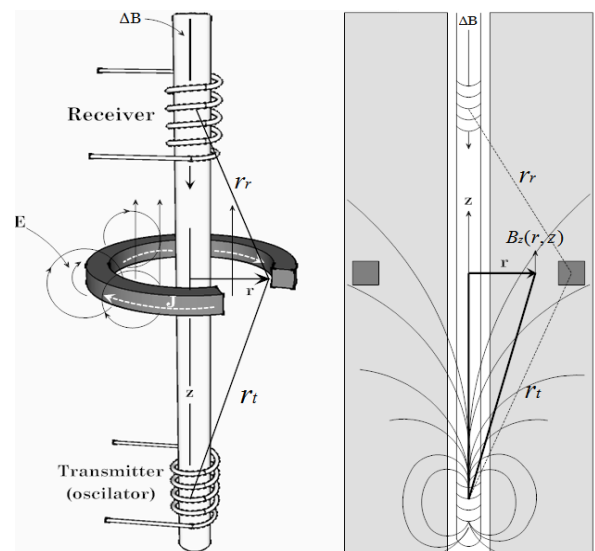

Figure 2 geometric factor calculating model, for two coil inductive probe [5].

## 4. THREE COIL INDUCTION PROBE

Inductive probe for resistivity measurements contains several separate units and circuits. In order to display design Fig. 3 shows block diagram of hardware realization of inductive probe. This version of probe is designed for laboratory testing and operation. Probe was realized so that the transmitter circuit generates alternating signal with constant amplitude and frequency of 20KHz, and passes it to the transmitting coils 'T' and 't'. These coils are connected in series and wound on the insulating probe body in opposite direction. Transmitter signal creates an electromagnetic field in formation, as previously explained in Chapter 2. Receiver 'R' detects the signal from formation, it is located at the distance L from main and L/2 from auxiliary coil.

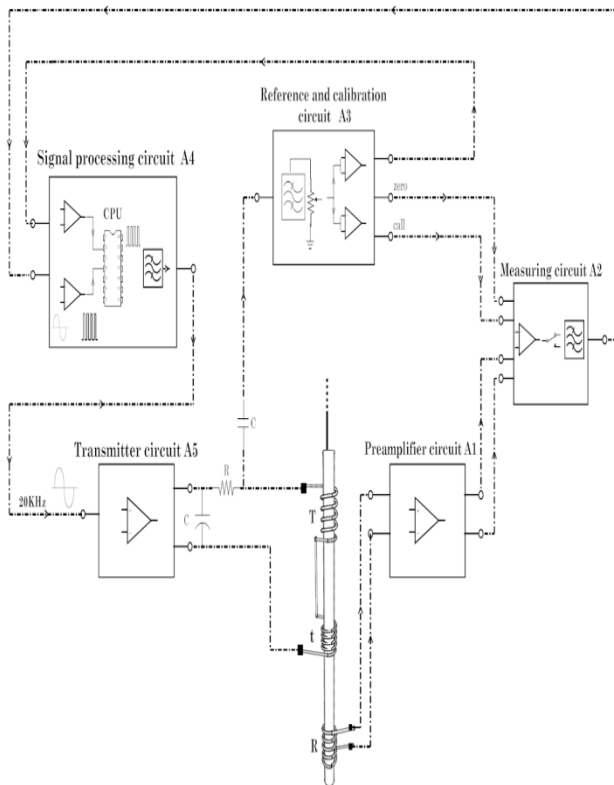

Figure 3. Induction circuit block diagram

Detected signal is sent to preamplifier circuit which significantly increase amplitude of the signal. After amplification, measuring circuit filters signal with the band-pass filter and send it to the signal processing circuit. CPU converts measured signal into digital form and sends data via serial communication to PC, it also generates a rectangular signal required to control transmitter circuit. Probe also contains reference and calibration blocks, these blocks provides the phase reference signal, internal calibration signal and 'zero' signal on its output.

Within this circuit internal phase-shift calibration is also performed.

## 5. HARDWARE DESCRIPTION

### 5.1. Transmitter circuit A5

The 20KHz sine wave signal provided by the signal processing circuit A4 is send to the input of transmitter. This signal is increased with non-inverting amplifier. Current buffer is used for power amplification of signal, amplitude of the signal stays unchanged.

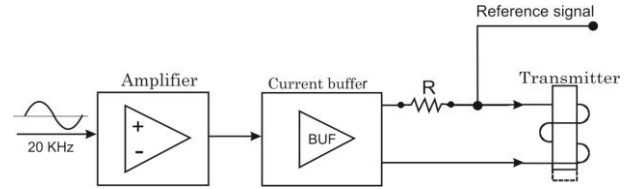

Figure 4. Transmitter block

After power amplification sine wave signal with amplitude in order of tens of volts is sent to the transmitting coils, which will create a variable magnetic field in the surrounding formation. Reference voltage for reference and calibration circuit A3 is measured on series resistance R.

### 5.2. Preamplifier circuit A1

Receiving coil is used to detect signal from formation, this signal is very low ( $\approx$  in order of mV) and needs to be increased. The pre-amp circuit receive signal from the properly balanced coil system. Accordingly, received signal are amplified by Amp 1 and Amp 2, amplification of Amplifier 1 can be changed, and amplifier 2 has a constant amplification. Both amplifiers are non-inverting.

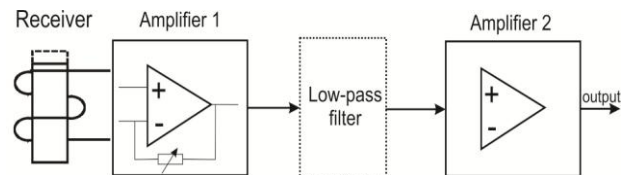

Figure 5. Preamplifier block

Low-pass filter is located between these two amplifiers, its purpose is to pass low-frequency signals and attenuate higher frequencies signals.

### 5.3. Induction measuring circuit A2

Three input signals leads to this circuit:

- 1 signal from preamplifier,
- 2 'zero' signal and
- 3 calibrations signal.

Input amplifier achieves amplification of signal with circuit A1. Amplified signal at output of A1 is superimposed with 'zero' signal at point 'S'. 'Zero' signal is used to calibrate probe in situation when the probe is located in the free space and measurements from the probe should be zero. Because of presence of metal parts in the probe, there are some signals in receiver coils, and 'zero' signal is superimposing with signal form the coil, so that the measured signal at point 'S' is zero '0'.

This circuit also enables switching between logging and calibration mode. Mode selection is realized with relay, which selects between preamplifier and calibration signal. Relay is controlled by microcontroller which is located in signal processing circuit A4, and the main command for selecting operation mode selection comes from a PC.

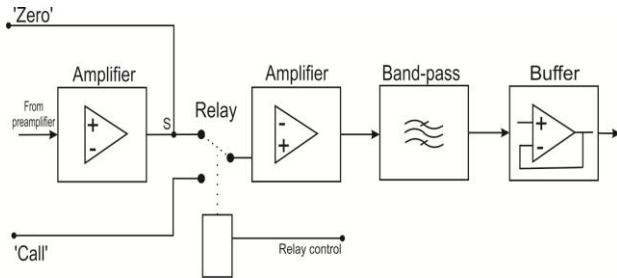

Figure 6. Induction measuring circuit block diagram

After the mode selection, signal is being amplified with inverting-amplifier and filtered by band-pass filter (with center frequency of 20KHz). Filter passes signals of interest and rejects (attenuates) frequencies outside of that range. At the output of this circuit final measurement signal is obtained and forwarded to the microcontroller.

#### 5.4. Signal processing circuit A4

The main element of this block is microcontroller, it regulates all processes and selects the working mode of probe via relay control.

Two signals are inputs for this circuit, one is measured signal from circuit A2, and the second is phase reference signal from A3. Since phase reference signal is sinusoidal, comparator is used to transform it to a rectangular signal. Microcontroller uses edges of this signal as phase reference, which is then used to determine sampling points of measured signal. Measured signal are sent to the buffer, to achieve good voltage source needed for proper AD conversion. AD conversion is made by controller, which samples the measured signal and send data via serial communication to PC.

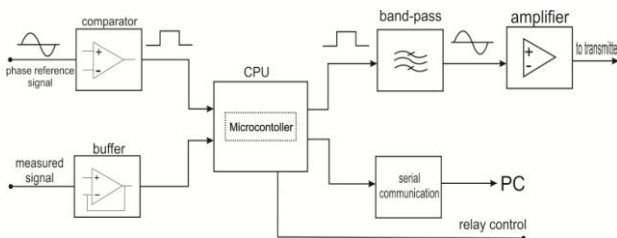

Figure 7. Signal processing block diagram

Microcontroller also generates a rectangular signal required for transmitter circuit. Frequency of this rectangular signal is 20KHz. Band pass filter of the same central frequency is used to filter this rectangular signal, rejecting its high frequency elements, to achieve sine wave signal on its output. The output signal is amplified with inverting amplifier to achieve higher amplitude, required for driving transmitter circuit.

#### 5.5. Reference and calibration circuit A3

This block provides three signals: the phase reference signal, internal calibration signal, and 'zero' signal. Reference voltage signal is taken from transmitter circuit.

Signal from transmitter circuit first passes through band-pass filter and then is being amplified with amplifier 1. The next step is the phase shift circuit which enables the phase change of phase signal. This allows us to adjust the phase reference, which is needed because of influence on phase of values of electrical components in the probe, which changes with the time.

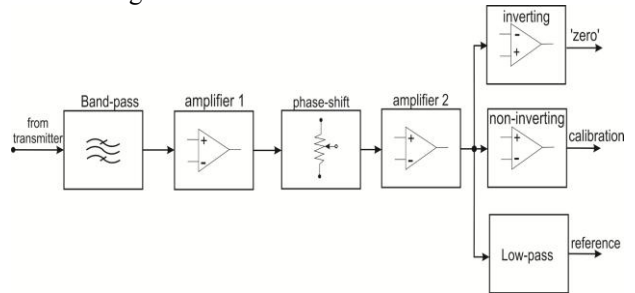

Figure 8. Reference and calibration block diagram

The output signal from amplifier 2 is divided into three different signals. One signal is sent to inverting amplifier and on its output it gives 'zero' signal. Second signal is sent to non-inverting amplifier, and he generates a signal for internal calibration of the probe. Third signal is the phase reference signal which leads to comparator, placed in circuit A4.

### CONCLUSION

The aim of this paper was to present brief introduction about the advantages and capabilities of inductive probe, and hardware realization designed to provide resistivity measurements in borehole logging. This probe is developed as prototype and tested in laboratory conditions.

### ACKNOWLEDGMENTS:

This paper is part of the projects "Development of methods, sensors and systems for measuring quality of water, air and earth", NO III43008, Ministry of science, Serbia.

### REFERENCES

- [1] W.C Duesterhoeft, Ralph E. Hartline, H. Sandoe Thomsen, The Effect of Coil Design on the Performance of the Induction Log, applied research associates of Texas Austin.
- [2] O. Serra. Fundamentals of Well-log interpretation, the acquisition of logging data.
- [3] Johannes B. Stoll, FE-Modelling of Induction Tool Responses, ANTARES Datensysteme GmbH, Rudolf-Diesel-Str. 6-8, 28816 Stuhr, Germany.
- [4] Dresser Atlas, 1971. Induction Log Interpretation.
- [5] G.Mančić, St. Martinović, M. Živanov, Geofizički karotaž – osnovni fizički principi, DIT Naftagas, Novi Sad, 2002.